

Design Description Document

“Beam Squad” Team

---

# In-vivo Thyroid Photoacoustic Camera

---

April 27, 2016

Customer: Dr. Navalgund Rao, Dr. Bhargava Chinni

Engineers: Zhenzhi Xia, Tim Ehmman, Jordan Teich, Guanyao Wang

Document Number 004

Revision Level: D

## Revision History

---

Revision Level	Content	Date
A	Updated CAD Model Analysis of Lightguide Structure	05/02/2016
B	Updated Laser Delivery Method and Results of Testing Added Beam Resizing Optics Added Gaussian Beam Model Updated Probe Geometry/	02/16/2016
C	Updated 3D Printing Plan for Probe Specification Sheet for Laser Source Added Updated Beam Diffuser Characteristics Updated Laser Reflector Specifications	25/02/2016
D	Results of Laser Reflector/ Reflectance Testing Final CAD Model Final LightTools Simulation of Probe and Laser Source Updated Component List Added List of Possible Future Improvements and Recommendations	25/04/2016

# Table of Contents

<b>I. Overview</b> .....	<b>3</b>
<b>II. BACKGROUND FOR CURRENT PROJECT</b> .....	<b>4</b>
HISTORY OF THIS PROJECT .....	5
<b>III. PRD</b> .....	<b>6</b>
<b>IV. SYSTEM BLOCK DIAGRAM</b> .....	<b>6</b>
<b>V. LASER DELIVERY SYSTEM DESIGN</b> .....	<b>7</b>
OVERVIEW .....	7
ARTICULATED BEAM ARM METHOD .....	8
LIGHTGUIDE METHOD .....	10
OPTICAL FIBER BUNDLE WITH MULTIPLE BEAMSPLITTER METHOD .....	13
<b>VI. IMAGING PROBE DESIGN</b> .....	<b>15</b>
OVERVIEW .....	15
PROBE CONFIGURATION .....	15
COLLIMATING OPTIC AND BEAM DIFFUSER.....	16
OPTICAL REFLECTOR.....	18
ACOUSTIC TRANSDUCER .....	20
CODEV MODEL OF ACOUSTIC LENS.....	20
<b>VII. PROTOTYPE DESIGN AND CAD MODELING</b> .....	<b>21</b>
DESIGN DETAILS .....	23
LIGHTGUIDE COUPLING.....	24
LIGHTTOOLS MODEL USING CAD MODEL.....	25
<b>VIII. 3D PRINTING PLAN</b> .....	<b>27</b>
<b>IX. TEST PLAN</b> .....	<b>28</b>

OVERVIEW .....	28
DETAILED TEST PLANS .....	28
<b>X. LASER DELIVERY TESTING RESULTS .....</b>	<b>30</b>
BEAM ARM METHOD .....	30
LIGHTGUIDE METHOD .....	30
LIGHTGUIDE WITHOUT RESIZING OPTICS METHOD .....	30
LIGHTGUIDE WITH RESIZING OPTICS METHOD .....	31
LIGHTGUIDE WITH COUPLING METHOD AND BEAM DIFFUSER .....	31
LIGHTGUIDE WITH COUPLING METHOD, BEAM DIFFUSER, AND PARTIALLY OPAQUE TPX .....	31
<b>XI. REFLECTOR TESTING RESULTS.....</b>	<b>32</b>
ALUMINUM/MYLAR FILM ON TPX .....	32
ALUMINUM COATED TPX .....	33
ACRYLIC.....	33
REFLECTANCE FOR OPTICAL REFLECTOR.....	33
<b>XII. TIMELINE .....</b>	<b>35</b>
<b>XIII. RISK ASSESSMENT .....</b>	<b>36</b>
<b>XIV. RECOMMENDATIONS .....</b>	<b>36</b>
<b>XV. FUTURE PLANS.....</b>	<b>37</b>
<b>XVI. APPENDICES AND REFERENCES .....</b>	<b>38</b>

## Overview

---

The in-vivo photoacoustic camera currently being researched has the potential to be a tool used in detecting early stage thyroid cancer. The camera is being developed under the supervision and with the help of Dr. Navalgund Rao, a professor in the Imaging Sciences Department at RIT, Dr. Vikram Dogra, a doctor in the Radiology Department at the University of Rochester Medical Center (URMC), and Bhargava Chinni, a researcher in the Department of Imaging Sciences at URMC. The goal of this project is to ultimately create an in-vivo photo-acoustic thyroid imaging system for use in a clinical setting, with the purpose of differentiating between normal and malignant tissue within the thyroid. This consists of a laser source, laser delivery system, an imaging probe, and a detector within the probe. The primary goals of this project are

- to determine the most efficient laser delivery system which will be used for delivering laser light to the imaging probe and the most efficient method for coupling laser to the lightguide.
- to design and build a prototype of the final imaging probe, which will connect to the laser delivery system and be placed, in-vivo, against a patient's neck. The entire beam delivery and imaging probe system should have less than 50% power loss and be readily sterilized and cleaned for use in-vivo

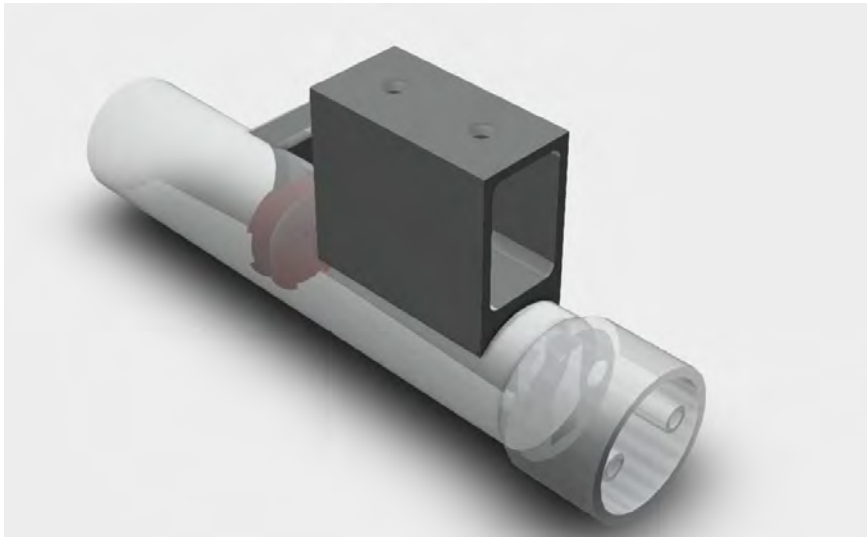

*Diagram of Overall System: EKSPLA Nd:YAG pumped OPO laser, resizing optics, connecting lightguide, imaging probe, ultrasonic transducer, and accompanying computer system for recording images*

## Background for Current Project

---

This project evolved from our customer's desire to image the human thyroid gland, in order to allow physicians to diagnose problems with in and around a patient's thyroid gland, such as cancer, abnormal tissue masses, as well as circulation problems. The probe that is described here is partially based on a previously designed ex-vivo probe for use in ex-vivo imaging of thin slices of thyroid tissue. The CAD model for this probe is shown below.



*CAD model created for previous, ex-vivo imaging probe, by a past member of the Rao/Dogra Lab.*

This previous probe design acted as the foundation for our design of the second 3D printed part in the overall probe, described in the “3D printing plan section”. This part is used to house the optical reflector, acoustic lens, and acoustic transducer and is very similar to the part shown above. However, in order to make the optical reflector easier to design, our team decided that it would be best make the probe rectangular, rather than round, like the probe shown above. This meant that the part that houses the reflector, acoustic lens, and acoustic transducer also had to be rectangular, rather than round. In addition, a 3 mm thick groove had to be constructed at the end of this piece, in order to hold the reflector at a 45 degree angle, allowing for proper reflection of the laser beam.

The acoustic lens (see red lens in the part displayed above) was chosen to be a singlet designed previously by Optical Engineering students working with the Rao/Dogra lab. This lens was designed to operate in a 4f system, where the object (tissue) is placed at a distance of 2x the focal length of the lens and the detector (acoustic transducer) is also placed 2x the focal length of the lens away, but on the opposite side of the lens. This produces an approximately collimated acoustic beam, incident on the transducer. The same lens is used in the current probe, designed by our team.

In regards to the image processing performed in order to create the final images, a MATLAB algorithm that was created previously by the Rao/Dogra lab, is used to create and display images of the acoustic signal received from the photoacoustic generation of sound waves. This MATLAB code

uses a method known as chromophore analysis to create images of four separate tissues found in and around the thyroid: fat, water, oxygenated, and deoxygenated hemoglobin. Each tissue absorbs light within the 760-1000 nm spectrum in different amounts. Therefore, the contributions of each tissue can be independently displayed and the physiology of thyroid and surrounding tissue can be determined based on these images.

## **History of This Project**

This project has been in development for quite some time, with a senior design team from the 2015 graduating class already working with our customers on a similar product. It was the responsibility of this team to aid in the design of a transrectal probe for imaging prostate tissue. This product would allow medical professionals to detect and diagnose disorders related to the prostate. Similar to our design of a probe for the thyroid, this prostate probe also worked on the principle of photoacoustic imaging. This past senior design team specifically worked on designing, manufacturing, and testing a lens system to be used for imaging the induced ultrasound signal from the prostate tissue onto an acoustic sensor. In other words, this team was working to design an acoustic lens system for the probe. This past work was extremely valuable to the workings of our current senior design team, as the work done to create an acoustic lens system was also pivotal to our success designing and manufacturing a thyroid imaging probe. The design of the acoustic lens system by this past team was used as the starting point for the acoustic lens system present in our project. Without the work completed by this team, it would have been much more difficult for our team to get a working thyroid imaging probe prototype off the ground

# PRD

See “In-vivo Thyroid Photoacoustic Camera Product Requirements Document”

## System Block Diagram

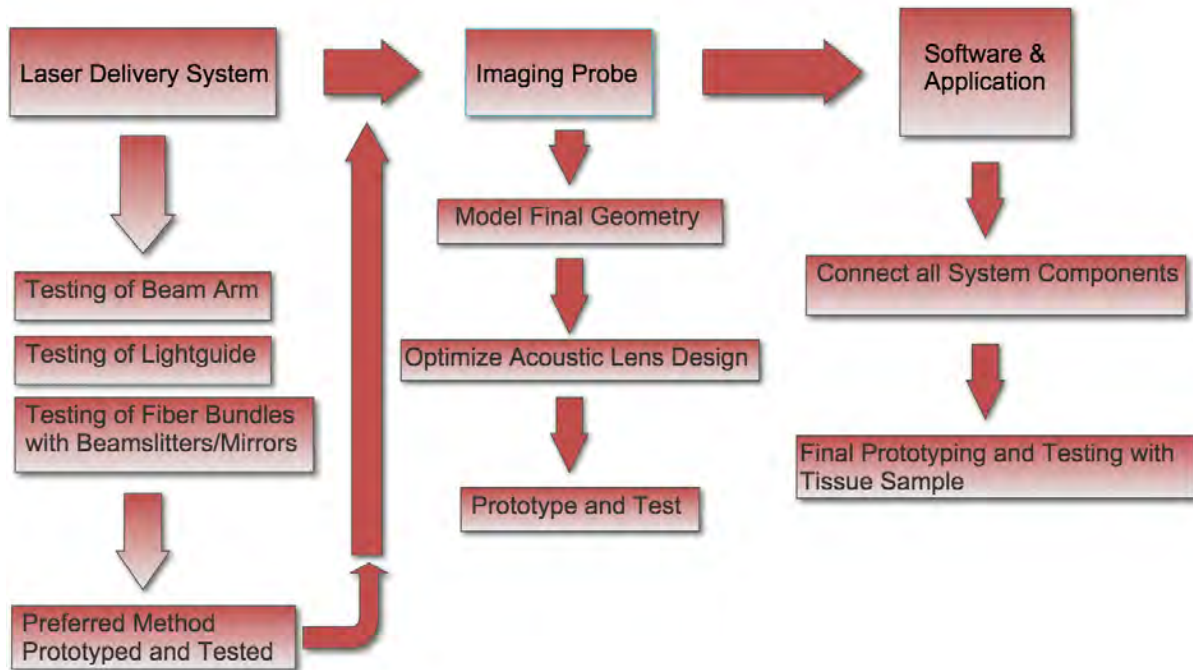



# Laser Delivery System Design

---

## Overview

We have been tasked with the creation of the laser delivery system which will transmit light to the imaging probe, preferably with <50% power loss. As we detailed last semester, we have considered using one of three delivery systems: an articulated beam arm, a lightguide, or a delivery system which consists of multiple beamsplitters and corresponding multimode fibers. We have tested the articulated beam arm with both a He-Ne laser and our customer's Tunable Nd:YAG laser system and have found that the beam arm will not be compatible with our customer's laser. We have tested the Edmund Optics lightguide, given to us by our customer, using primarily our customer's laser, tuned to 760, 800, 850, 930, 970 and 1000 nm. We have found that although the lightguide transmits less than 50% of light for the wavelengths 850, 930, 970 and 1000 nm, we are able to achieve close to 50% transmission through the lightguide by implementing a two lens focusing system, placed between the laser and the lightguide. In terms of photons, this means that at a wavelength of 850 nm, our customer's laser is producing about  $1.7 \times 10^{17}$  photons and the lightguide reduces this number to about  $7.9 \times 10^{16}$  photons, which is slightly under 50% of the original photons. Our customer has not yet told us how much light is enough to produce a clear image. Instead our only clearly defined restriction for the transmission of light through the system is to get transmittance values at or less than 50%. Therefore we are right around the desired value of transmittance for our imaging probe. Based on our transmission results via the lightguide and the fact that our customer wants a working prototype by the end of the semester, we have agreed to move forward with the design of the final imaging probe, using the lightguide as our delivery method.

## Source Laser Specifications

The specifications for our customer's laser are given below:

Wavelength (nm)	Divergence (mrad)	Beam waist (mm)	$M^2$
760	< 0.5	5	20.7
800	< 0.5	5	19.64
850	< 0.5	5	18.48
930	< 0.5	5	16.89
970	< 0.5	5	16.20

## Articulated Beam Arm Method

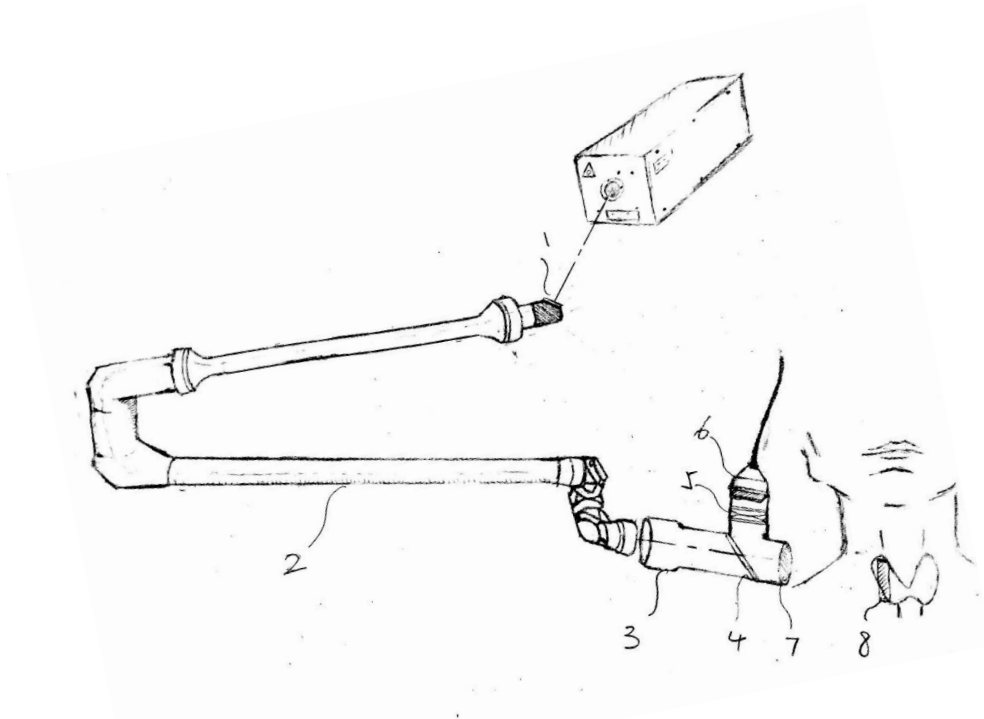

*Above: Laser Delivery Configuration, in which the laser source is coupled into the articulated beam arm and is delivered via beam arm to the 3D printed probe, through which it is delivered to the thyroid*

The articulated beam arm offers high power transmission for visible and near-infrared wavelengths, due to its utilization of gold plated mirrors that can be coated for  $> 97\%$  reflectivity. Unfortunately, the beam arm suffers from two main problems: 1.) limited mobility and 2.) a problem transmitting our customer's laser. The latter of these two problems is related to the amount our customer's laser beam diverges while in the beam arm and the fact that the entrance face of the beam arm is smaller than the 8 mm diameter beam diameter of our customer's laser. This means that prior to entering the beam arm, we are losing light. It also means that once inside the beam arm, the laser beam might be hitting the sides of the arm and therefore terminating prior to exiting the arm. This problem is reflected in our data, presented in the "Testing Results" section below. We have tested the transmission of the beam arm with a He-Ne and an infrared laser, as well as the tunable Nd:YAG laser provided by our customer. The data we collected clearly shows that the beam arm works well with the He-Ne and infrared lasers, which produce a much smaller beam spot and a much less divergent beam. However, upon switching to our customer's laser, our power loss neared 99%. The beam arm has not shown any mechanical damage to its exterior and we have assumed that no significant damage has been rendered to the arm. Therefore, the mirrors, pictured in Figure 2 below, should be aligned at

least fairly accurately. This high power loss. This means that the beam arm appears to be incompatible with our customer's laser.

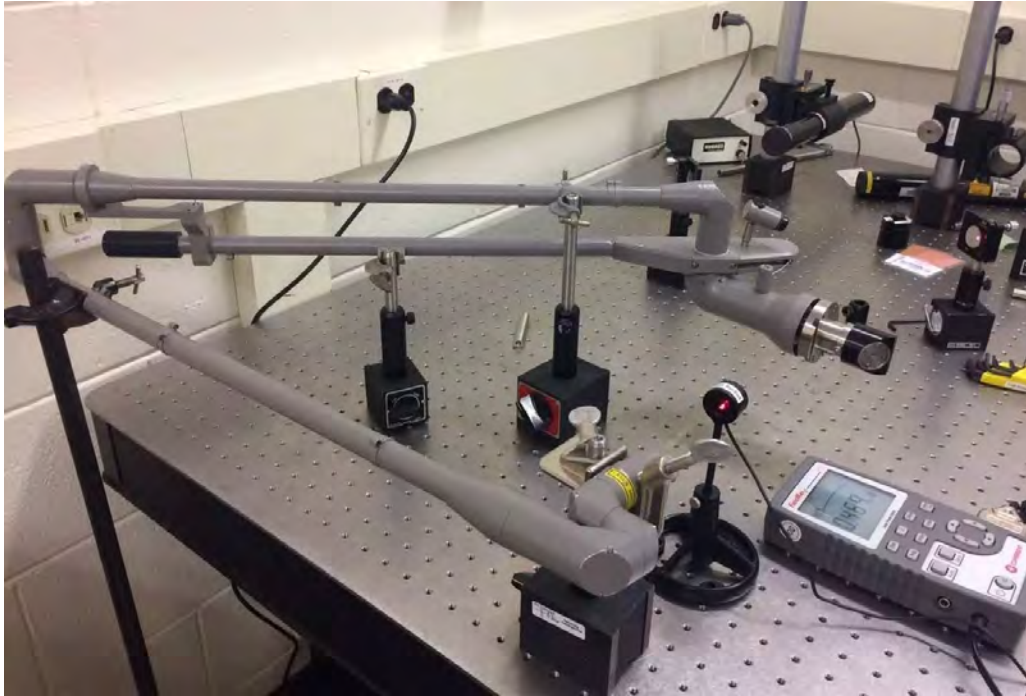

One of the gold plated mirrors present in the articulated beam arm. These mirrors are positioned throughout the beam arm and positioned such that regardless of the position of the beam arm, these mirrors will stay aligned.

## Lightguide Method

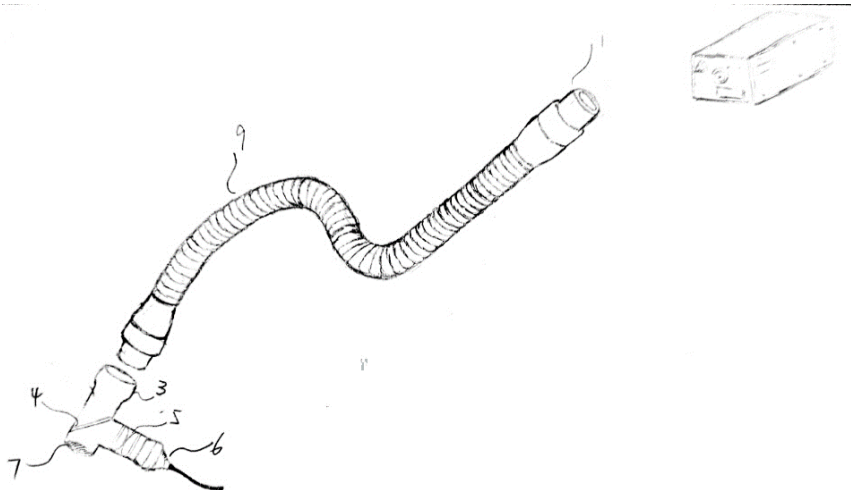

*Lightguide layout of in-vivo photoacoustic camera*

Considering the flexibility and ease of use for clinical setting, this 1.22m long, 6.35mm diameter lightguide (detailed specification see Appendix A) is a good option. We have been able to achieve close to or less than 50% loss for all of the wavelengths that will be used in the imaging process, which is an approved amount of loss for our customer and was our main concern for using the lightguide. This power loss was achieved through the use of a two lens coupling system, positioned between the laser and the lightguide, which serves to focus the 8 mm beamspot down to a beamspot that is less than 6.35 mm, the diameter of the lightguide. The specifications for these lenses are given below.

The two lenses used in this coupling system are as follows:

	Focal Length (mm)	Diameter (mm)	Material	Singlet symmetric concave/convex radii (mm) *	Coating
Lens 1	156	50	BK7	160.68	none
Lens 2	-100	50	unknown	103	Single layer MgF2 AR

\* from calculation instead of official specification



*Laser exiting the lightguide; uniformity does not seem to be a problem when using the lightguide and two lens coupling system.*

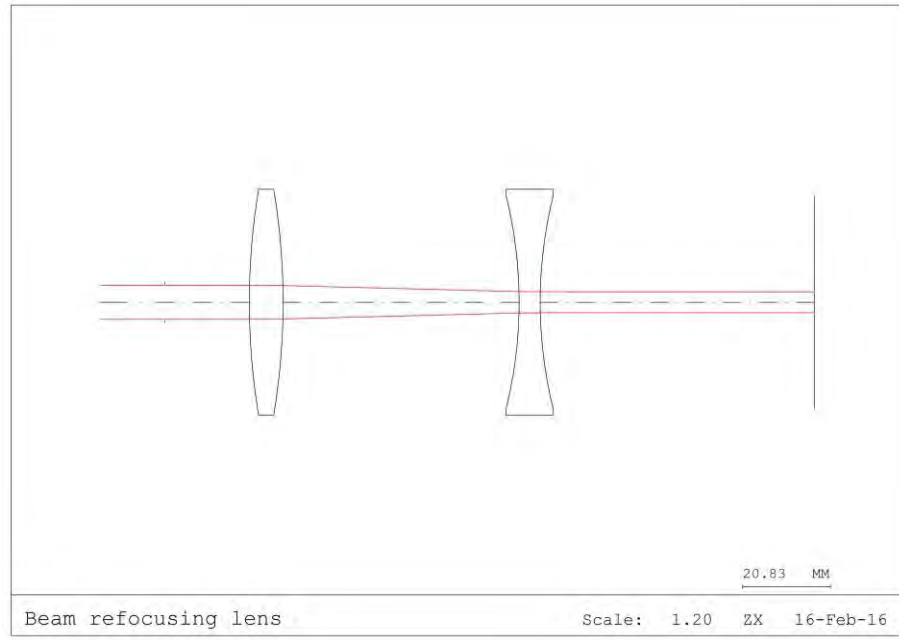

*CodeV model of two lens, resizing coupling system.*

Using the beam resizing optics, the initial beam diameter of 8mm is reduced to 5.39mm. Comparing this to the 6.35mm diameter for the lightguide, we can say that this is good enough to collect most of the incident laser light. The calculations performed in order to determine how to position our lenses so that they would produce a beam with a diameter  $< 6.35$  mm are shown below, performed using an online simulator.

In order to verify that the lightguide is receiving the maximum amount of light from the beam, calculations for determining the desired beam waist diameter and beam waist positions are performed. Due to the physical limit of the distance, the first lens is fixed to be positioned 65mm away from laser. The Gaussian approximation is used here for experimental purposes. The laser beam we are using is not actually diffraction limited, based on the  $M^2$  values calculated earlier. However, for the purposes of changing the size of the beam, a Gaussian approximation is sufficient.

### Gaussian Beam Parameters

Incident Beam Diameter: 8 mm

Incident Beam Divergence: 5 mRad

Enable Object Placement

Lens Element	Lens Focal Length (mm)	Lens Separation (mm)
1	156	65
2	-100	59

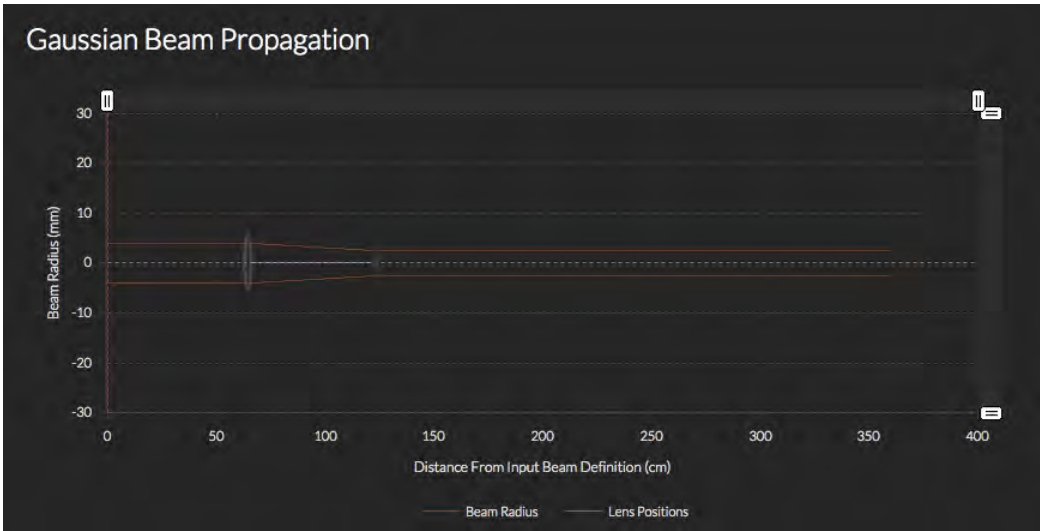

Note: this calculation is only valid for paraxial rays and where the thickness variation across the lens is negligible.

Lens Element	Beam Diameter At Optic (mm)	Beam Divergence (mRad)	Rayleigh Range (mm)	Beam Waist Diameter (mm)	Beam Waist Location (mm)
1	8.007	51.365	15.161	0.779	155.138
2	4.999	8.036	619.391	4.978	57.791



The effect of non-perfect packing efficiency and uneven arrangement of the fibers could result in a non-uniform illumination even when the laser enters uniformly. There is a very small tolerance on the illuminated area where light could fall on based on the figure on the right. In order to fix this uniformity problem, we placed two lenses after the light guide. The first had a focal length of 45 mm and a diameter of about 50 mm and the second had a focal length of about 37 mm and a diameter of about 45 mm. By placing the second lens 82 mm away from the first lens, we were able to collimate the beam exiting the light guide. This should produce a more uniform, focused beam with which to

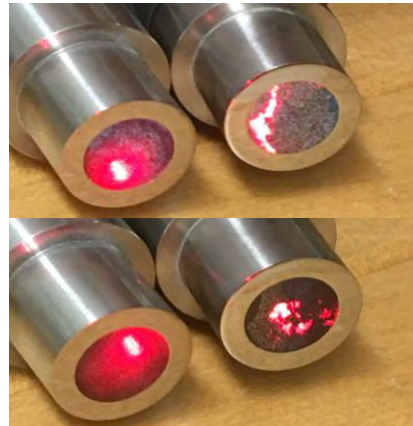
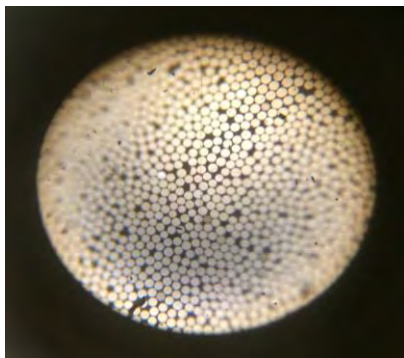

*Left: Image taken with lightguide placed under a microscope; Right: Red laser pointer is inputted on the left and a very diffuse beam is outputted on the right*

shape via beam diffuser. However, we may end up scrapping this collimation lens system due to its effect on the overall beam shape, which is discussed more later on in this document.

### **Optical Fiber Bundle with Multiple Beamsplitters Method**

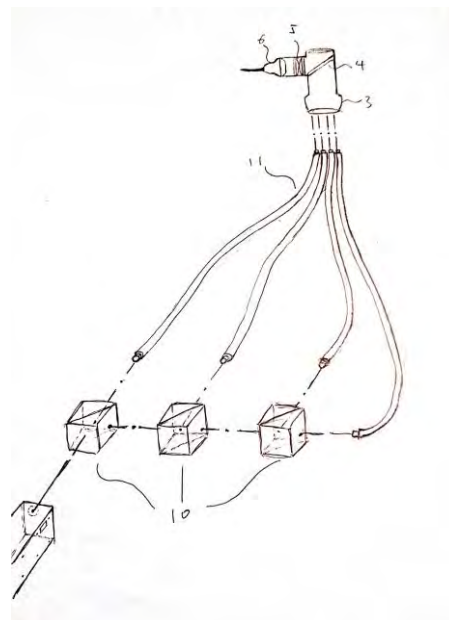

Optical fiber bundle with beamsplitters layout of in-vivo photoacoustic camera

In this method, we would divide the laser beam into multiple, lower power beams, through the use of multiple beamsplitters, and refocus each secondary beam into a single optical fiber. This would cut down on power loss through the system and would allow us to directly influence the shape, size, and uniformity of the final laser beam entering the probe. It would also prevent the destruction of each single fiber due to the division of the laser's power over multiple fibers. The number of beamsplitters and fibers is based on the damage threshold of each fiber and the output power of the laser. While such a method can allow for a large amount of flexibility, efficient coupling of fibers to the beamsplitters is difficult and time consuming and if done improperly, would result in higher power loss.

The method outlined above would take a large amount of time to assemble and test and due to the fact that our customer wants a working prototype by the end of the semester, this method was not feasible. This left our team with two options for the laser delivery system: the articulated beam arm and the lightguide. Due to the fact that our customer needs a probe that can be easily maneuvered in all three directions and does not impede the physician's ability to image the patient, as well as the fact that the articulated beam arm was proven not to function properly when paired with our customer's laser, as shown in the "Testing Results" section below, our customer decided that it would be best to use the lightguide as our laser delivery method.



# Imaging Probe

## Overview

As an in-vivo product, the imaging probe that is placed against the patient's neck will be handheld and portable. It will be watertight and will prevent stray light from exiting the system, once the laser is turned on. The probe itself was 3D printed by the company 3D Systems and will allow for the insertion of the necessary lenses, beam shaper, and plastic reflector (see diagram below).

## Probe Configuration

The probe contains a thin plastic plate included in the probe, which acts as an optical reflector. We have decided on the configuration of the final imaging probe, shown below.

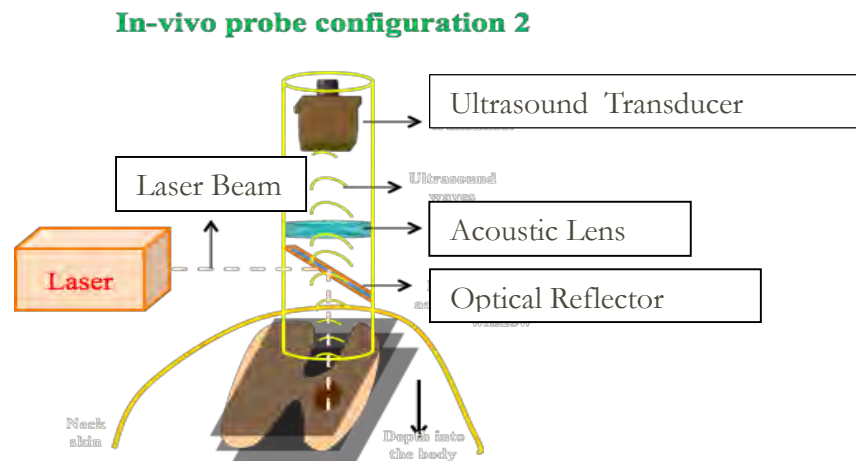

Laser is reflected by a coated plastic reflector and the generated ultrasound wave is transmitted through this same plastic reflector

The configuration shown above was chosen for two reasons: 1.) our customer has characterized the transmission of ultrasound through the TPX plastic proposed for usage as the optical reflector and has found that it easily transmits ultrasound and 2.) the ultrasound wave will not experience a noticeable amount of refraction through the optical reflector. According to our customer, he believes that the multiple reflections that the laser beam may experience upon reflection from the optical reflector will not affect the final image and is preferable to having the ultrasound wave experiencing multiple reflections. In addition, any refraction of the ultrasound wave through the optical reflector can be compensated for via the imaging processing methods used by our customer in MATLAB and thus does not pose a serious problem for our imaging probe.

## Collimating Optic and Beam Diffuser

Upon exiting the lightguide, the laser beam will be collimated using a 1 inch diameter, 25.4 mm focal length plano-convex lens. This will significantly reduce the divergence of the laser exiting the lightguide, which would otherwise diverge quite quickly. An Engineered Beam Diffuser, purchased from RPC Photonics, will then be inserted after the collimating optic and will be used to reshape the laser beam from a circular beam into an approximately linear beam shape. In order to determine the divergence angle of the necessary diffuser, our team performed the first order calculations, given below.

In order to determine the beam diffuser with the appropriate divergence angle, we performed the following first order calculations.

The distance from beam diffuser to reflector=27mm

The distance from the reflector to the neck=35mm

The range of laser pattern=8mm~24mm

$\tan(\text{divergence angle of beam diffuser})$

$$= \frac{\text{laser pattern size}}{\text{distance from beam diffuser to reflector} + \text{distance from the reflector to the neck}}$$

We picked the smallest size to do the calculation, because we can simply increase the distance from the beam diffuser to reflector to increase the laser pattern size.

$$\tan(\text{divergence angle of beam diffuser}) = \frac{8\text{mm}/2}{27\text{mm} + 35\text{mm}}$$

$$\text{divergence angle of beam diffuser} = \tan^{-1}\left(\frac{4\text{mm}}{62\text{mm}}\right) = 3.691^\circ$$

After we determine the divergence angle of beam diffuser, we want to check whether the tube would block the beam. The tube we are using is 2 inches long with 1 inch diameter.

$$\tan(3.691^\circ) * 50.8\text{mm}(2 \text{ inches}) * 2 = 4.916\text{mm} * 2 = 6.554\text{mm} \approx 0.26 \text{ inches}$$

According to the calculation above, the tube would not block the beam, no matter where we place the beam diffuser.

Based on these calculations, our team chose to use the EDL-4 beam diffuser, which corresponds to a divergence angle of 4.5 degrees at the full width half max. While these calculations show that the beam should theoretically be around the size that we want it (8 mm x 1 mm), the beam begins diverging once it exits the beam diffuser and continues to diverge over the distance from the reflector to the face of the tissue. Given that the EDL-4 produces the smallest angle of divergence offered by RPC Photonics, our probe will not be able to produce a beam that is the size of the current acoustic transducer, based on the inherent limitations of the RPC diffusers. Using this diffuser, the beam that is incident on the tissue will, in fact, be about 20-25 mm x 4-5 mm. While this is not the desired size of the active area of the transducer, as mentioned above, it will allow for a transducer with a large active area to be used for imaging; our customer has told us that he plans to order such a transducer for future imaging and therefore the beam incident on the tissue would need

to be larger in order to fill the detector. This means that our probe will allow for various acoustic transducers to be used for imaging of thyroid tissue. Using the EDL-4 diffuser, our probe will overfill the detector, meaning that there will be wasted signal in the system, i.e there is signal that is not collected by the acoustic transducer. However, this is not a significant concern for our customer; instead our customer is more concerned with optical power transmission through the system and laser beam uniformity at the face of the tissue. Given that the beam diffuser produces <10% power loss, this beam diffuser will not produce significant power loss in our system. The image below shows the laser beam, incident on a piece of paper (in order to visualize the beam), after passing through the collimating optic, beam diffuser, and reflecting off of the optical reflector. This image shows that our system, including the beam diffuser, produces a mostly uniform beam across the illuminated area. Therefore, uniformity of the laser beam incident on the tissue is not an issue for our system.

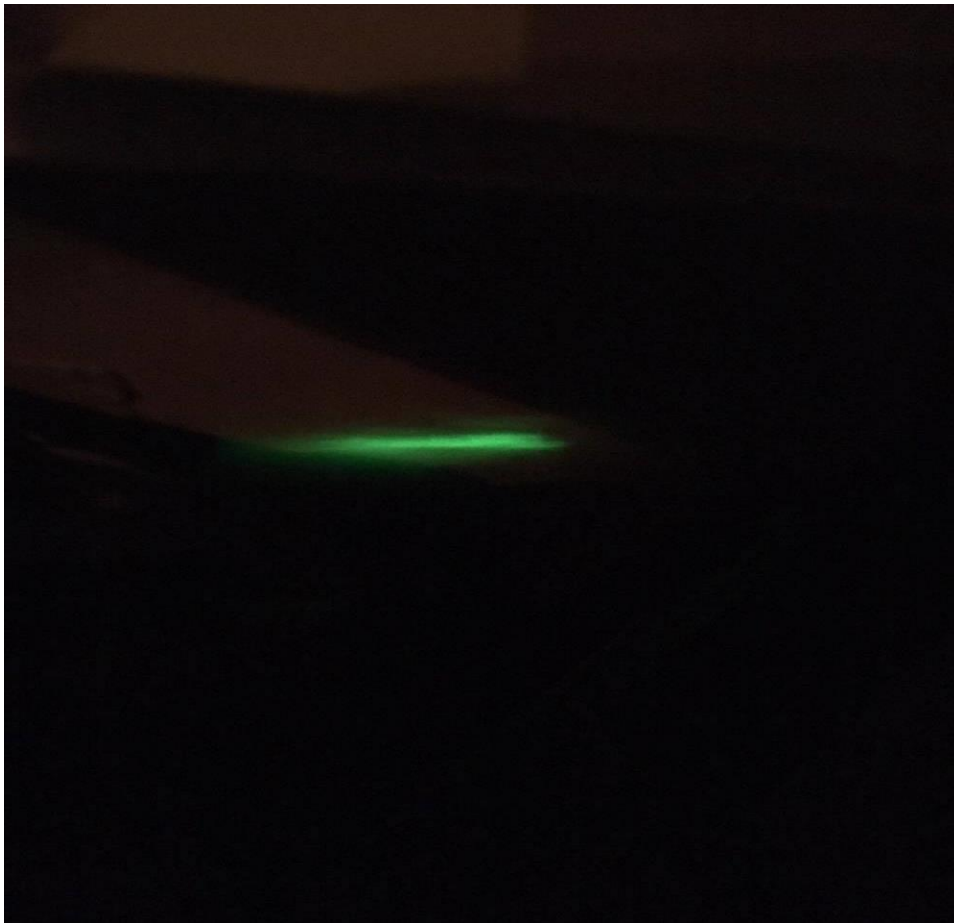
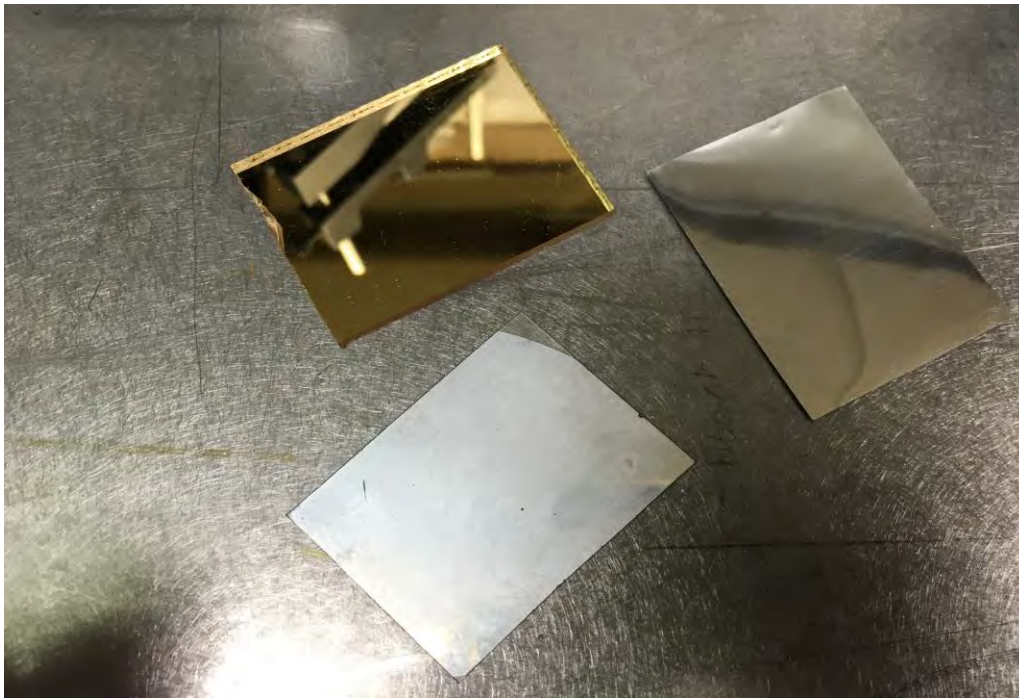

*Image of laser beam; here the laser is passed through the lightguide, the collimating optic, and the beam diffuser, before being reflected onto the paper used as the imaging plane.*

## Optical Reflector

The optical reflector for our system needed to be plastic and as reflective as possible (>90% if possible). The material for this reflector needed to be a plastic with an acoustic impedance similar to that of water ( $z = 1.5 \text{ Mrayl}$ ), due to the fact that the probe will be filled with water, in order to allow for maximum transmission of ultrasound signal through the probe. Therefore, our customer specified that, if possible, the reflector should be constructed out of TPX ( $z = 1.8 \text{ Mrayl}$ ). This plastic is not a plastic that is commonly coated or used to make optical devices or components. Acrylic ( $z = 3\text{-}3.2 \text{ Mrayl}$ ) and polycarbonate ( $z = 2.7 \text{ Mrayl}$ ) are the most commonly used plastics for the production of plastic optical components, such as mirrors and coated flats. Our team was not able to find any plastic optics companies either in Rochester or outside of Rochester that would be able to produce a TPX piece with a high reflective coating, nor were we able to find a company that would produce a small piece of either acrylic or polycarbonate coated with a high reflectivity coating within our budget (<\$1000) and time frame (<1 month).

Due to our inability to find a company that could make the reflector, our team chose to produce our own pieces. One of the reflectors we have produced is a 36 mm x 48 mm x 0.52 mm piece of TPX, coated with a reflective Aluminum coating, in the UR Nano-lab, which was made by Brian McIntyre. The second reflector that we produced was a 36 mm x 48 mm x 0.52 mm piece of TPX, covered with a thin (1 mm) piece of Aluminum coated Mylar film. The third reflector that we chose to use was a 36 mm x 48 mm x 3 mm piece of FABBACK acrylic mirror; this acrylic was sold as a sheet mirror by the PLASKOLITE company and was intended for use as a highly reflective mirror. These three reflectors are presented below:



*Top Left: Acrylic Mirror, Top Right: Mylar Covered TPX, Bottom: Aluminum Coated TPX*

The limitations to the Aluminum coated TPX reflector are primarily that the film is very thin and therefore can be easily scratched and destroyed, as well as burned off if the laser fluence is too high (>20 mJ/pulse). The primary limitation of the Mylar covered TPX reflector is that the Mylar is currently attached to the TPX via tape, which is susceptible to water and therefore can be eroded. While the acrylic mirror reflector offers the best mechanical stability and is not as susceptible to damage, the acoustic impedance of acrylic is not ideal and would produce a much higher reflection of acoustic signal, if used. In addition, the acrylic is much thicker than the other two reflectors and therefore would attenuate the acoustic signal much more than the other two reflectors.

Although the limitations listed above appear to prove that the TPX reflectors are best suited for our system, our testing results show otherwise. The Mylar covered piece of TPX performed the best for overall transmission of optical power. At 760, 800, and 850 nm, the acrylic mirror worked better than the Aluminum coated TPX, but at 930 and 970 nm, the Aluminum coated TPX worked better, in regards to overall power transmission. However, in regards to overall beam quality, the Mylar covered TPX worked best, while the acrylic also worked well, but the Aluminum coated TPX fell short and produced a dimmer, less uniform beam. Therefore, the most suitable reflector for our system, both mechanically and optically would be the acrylic mirror. However, if we need better acoustic transmission, we can use the Mylar covered TPX.



## Acoustic Transducer

The acoustic transducer will be supplied by our customer and will not be an issue with regards to our optical design nor the design of the imaging probe as a whole. This transducer functions as the detector for the acoustic signal generated by the tissue. The transducer that will be used with this probe will have an active area of 1 mm x 8 mm. The transducer is shown in the figure below, on the right side. A picture of the proposed slot in which the transducer will fit is shown on the left.

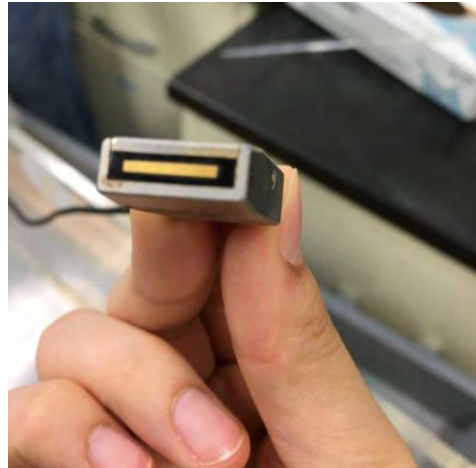
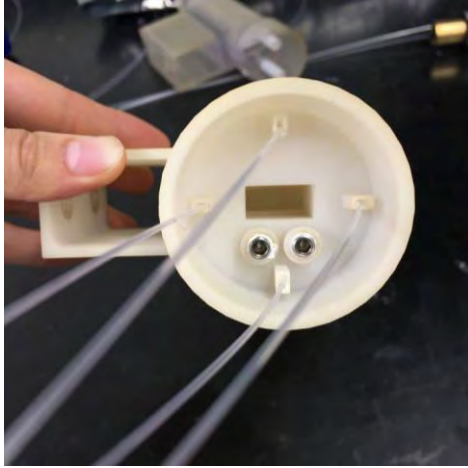

## CodeV Model of Acoustic Lens

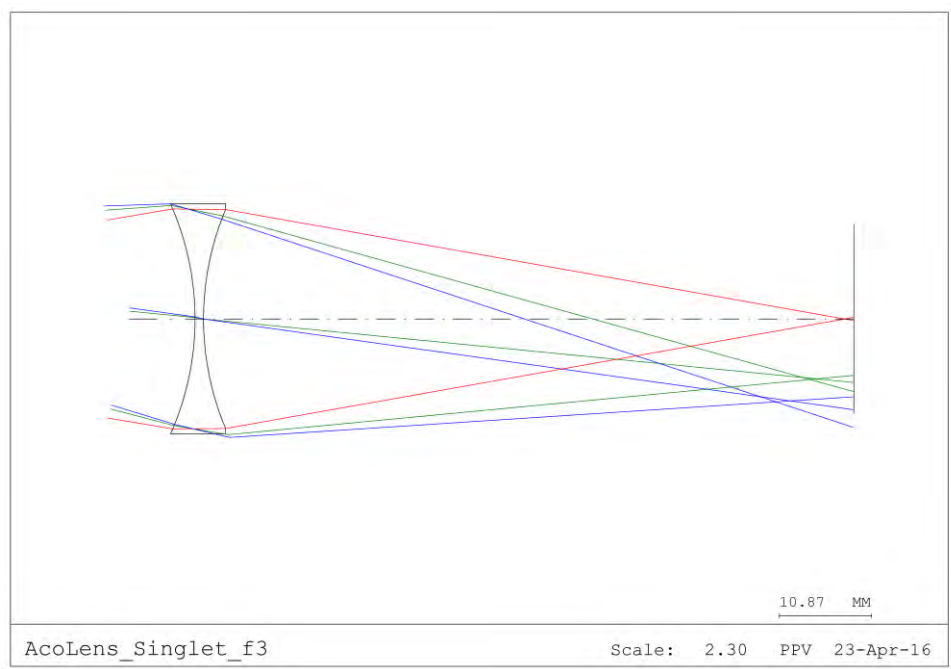

## Prototype Design and CAD Modeling

First of all, the probe shape has been changed from a cylinder to a square column mainly due to 1) less uncertainty from misalignment will be introduced to the system as circular design gives more degrees of freedom, especially with rotational axis 2) the microscope slide and reflectors of square shape are easier to further modify ourselves and will require less tight tolerances. However, the tradeoff is that we need to build supporting frames around the acoustic lens so that it doesn't fall off during the 3D printing process, as well as the square hollow-like filling material around the circular lens tube to stabilize the tube from moving off optical axis. Compared to last year's ex-vivo model, the new in-vivo model has been changed in the following aspects:

4f system of the acoustic lens

- choice of probe configuration (mentioned in previous section)
- mechanical mounting for reflector, beam shaper and collimation lens
- coupling of the lightguide to the side of the probe
- water sealing
- flexibility to replace and realign the optical parts

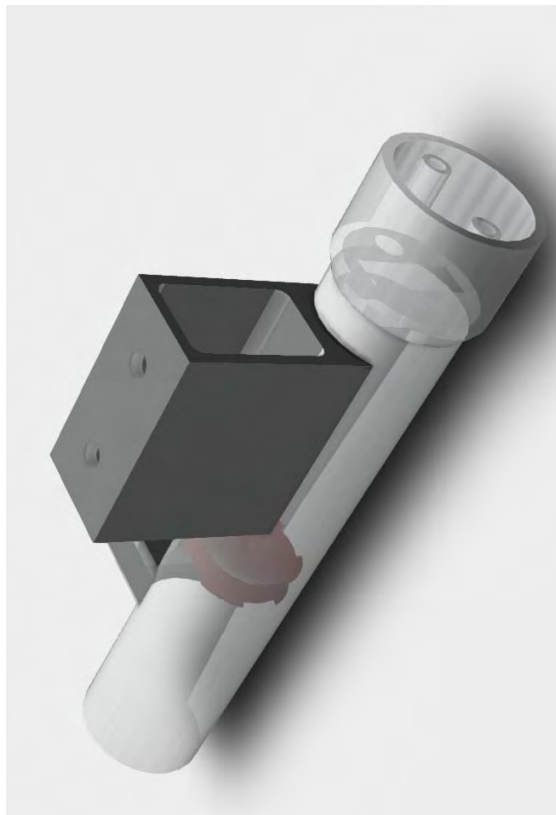

Ex-vivo setup 2015

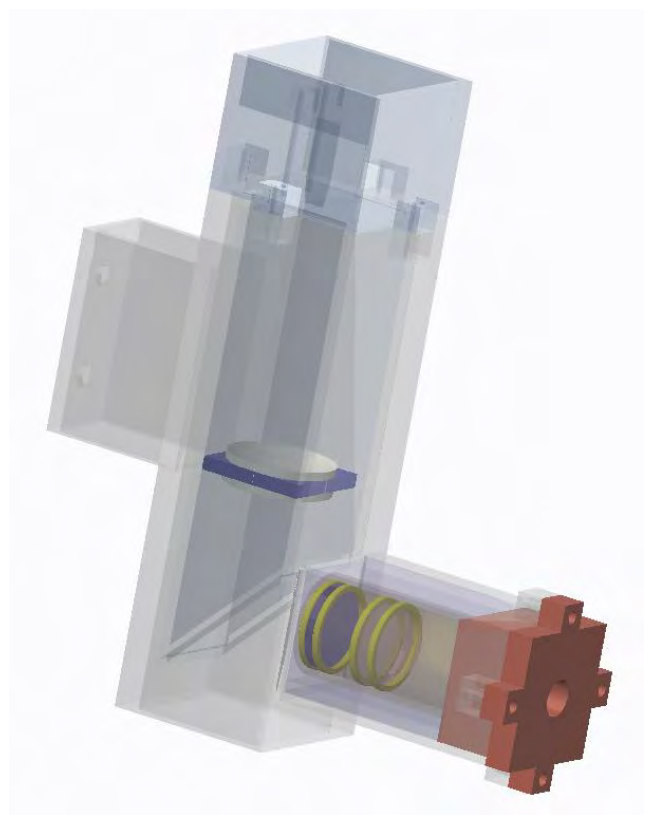

In-vivo setup 2016

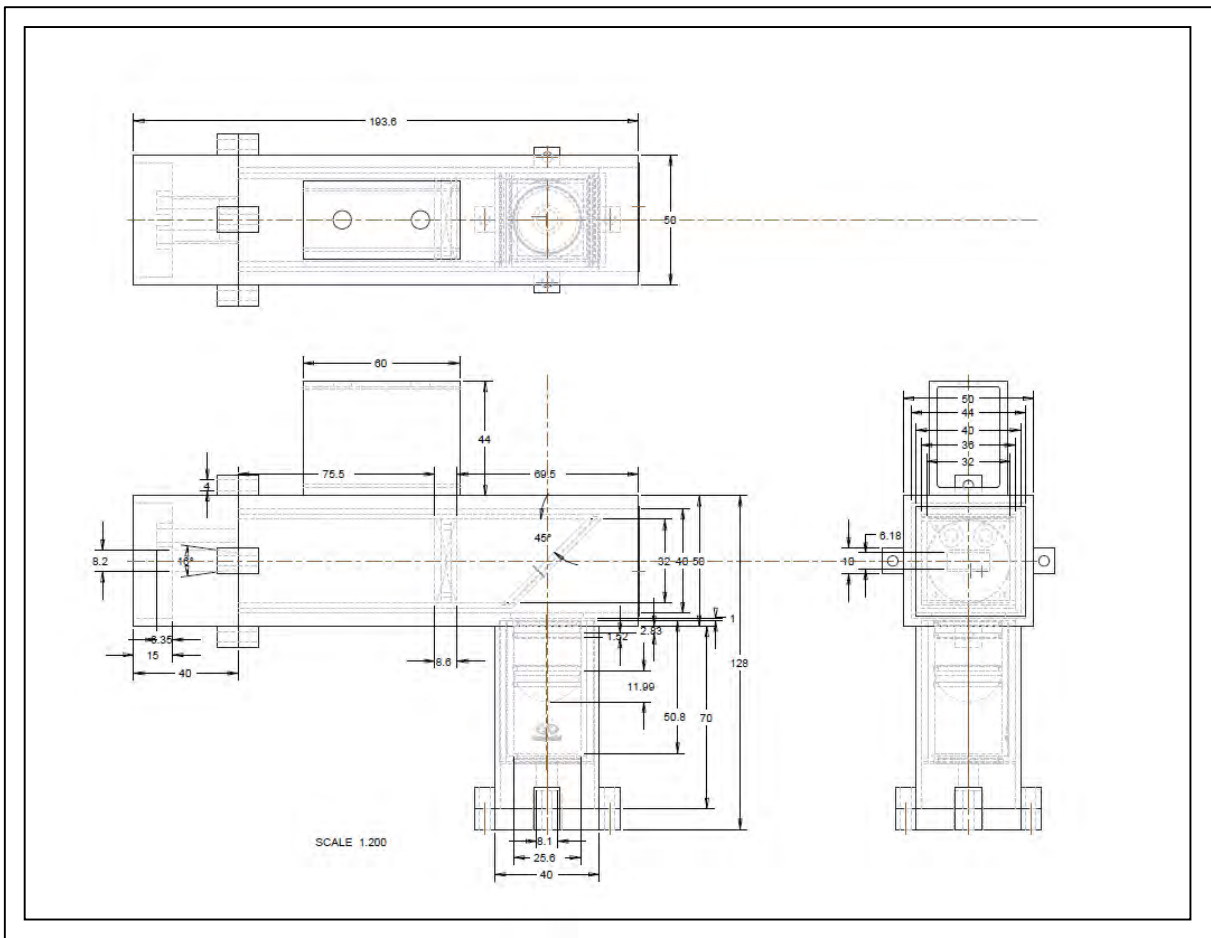

Mechanical drawing of the in-vivo imaging probe in three views

The new prototype is no longer one single part, but comprised of four main parts that are 3D printed and will be assembled upon arrival. They are the 1) Innerprobe, 2) Outerprobe, 3) Lens tube filling, and the 4) Lightguide Coupler, as shown in the figure below.

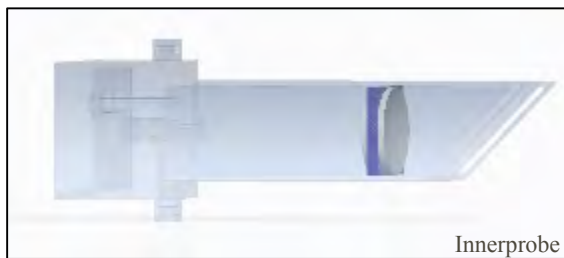

Innerprobe

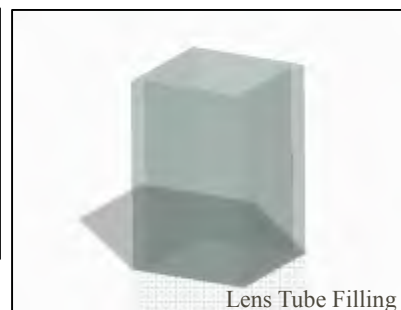

Lens Tube Filling

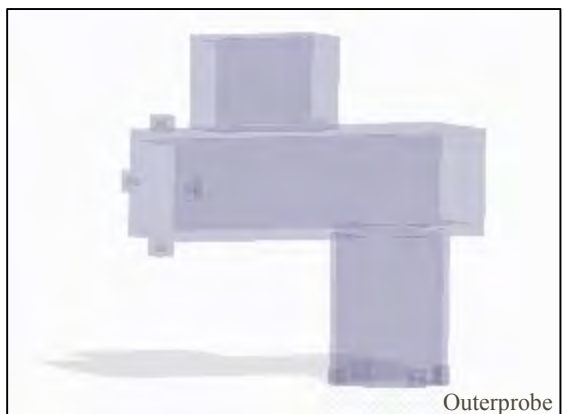

Outerprobe

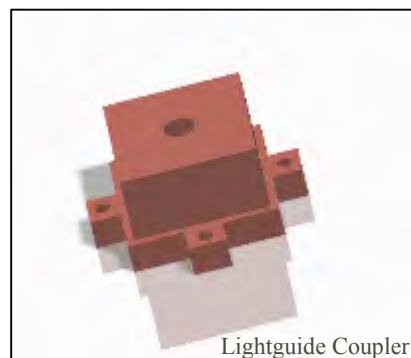

Lightguide Coupler



## Design Details

### *4f System*

As the customer's request, the 39.9mm focal length acoustic lens designed from last year is at a 4f optical system.

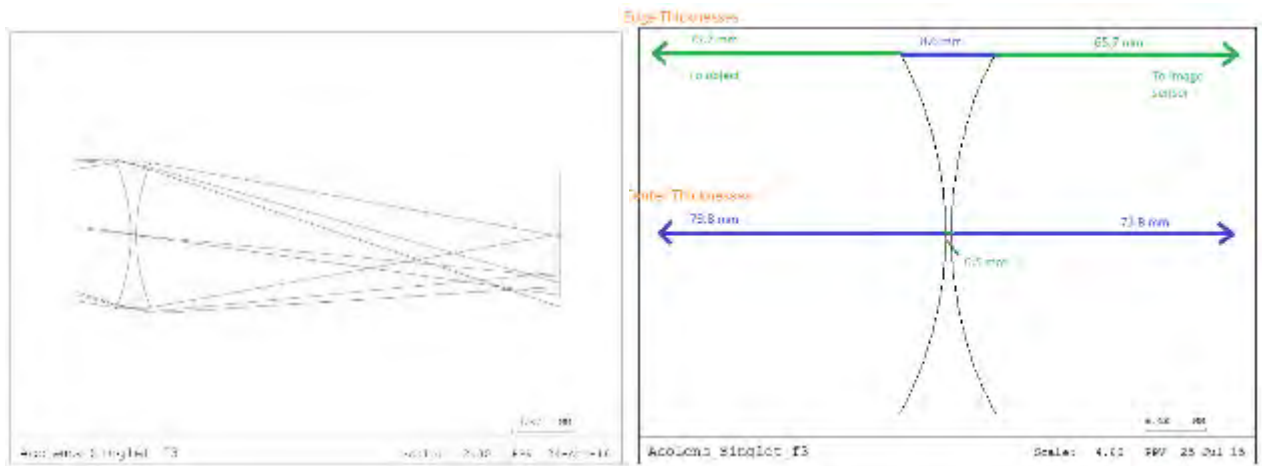

A very thin rubber sheet will be inserted between the inner and the outer probe in order to make the probe water proof. The two probes will be joined by four screws on the side. We make sure that the distance from the object, which is human thyroid tissue to the center of the acoustic lens is 79.8mm, the same as the distance from the center of the lens to the image plane, which is the transducer in this case. Considering the clinical use that the probe won't be utilized tightly against patient's neck, we leave the distance from the end of the outerprobe piece to the lens centerline 6mm thinner, which is 73.8mm.

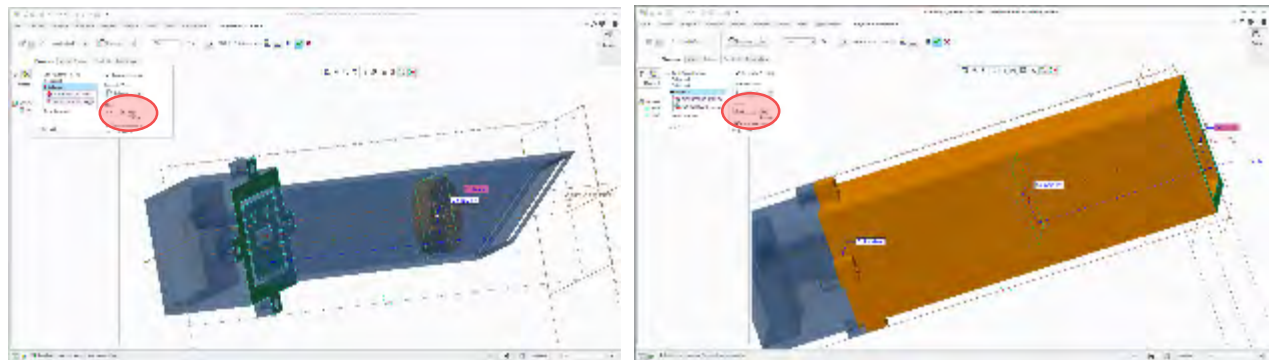

### *Coupling of the "Laser Delivery" Part*

According to LightTools simulation and the actual lab settings, to get the maximum energy from the initial laser to human tissue, we want to minimize the distance between the top of the reflector groove and the right end of the outerprobe piece. But considering our customer will run experiments on the phantom that is placed inside a vessel, we leave a distance of 15mm for the probe to go into the vessel and this is where the probe that delivers laser connects to.

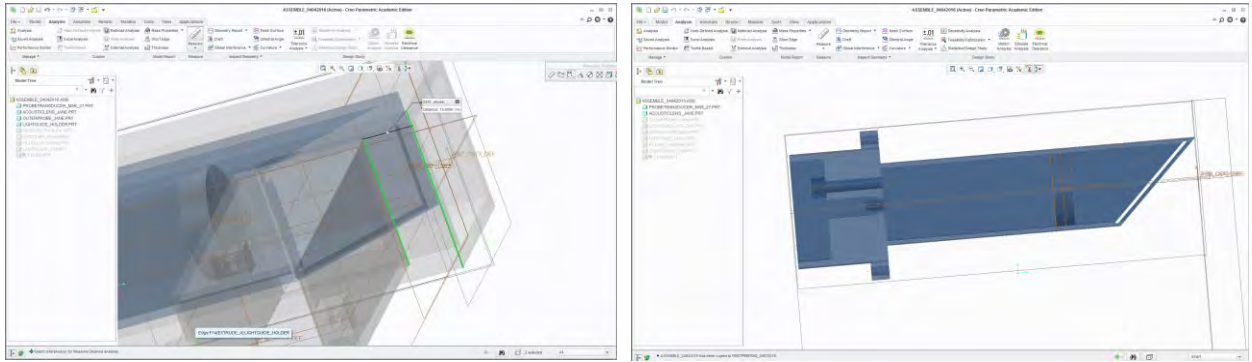

### *Reflector Groove*

The reflector groove width is defined to be 3mm in the z direction. The innerprobe piece is cut only on the left and right side but the top and the bottom parts remain closed ends. This provides the advantage that the reflector will be replaceable and after the outerprobe piece is connected, the reflector will have no space to move around. Therefore the 45 degree placement is securely ensured.

### *Lens Tube and Filling Frame*

For the sake of giving more flexibility to the energy focusing and beam shaping, we adopt a 2-inch lens tube from Newport instead of 3D printing the mechanical mountings for the optics. However, to keep the optical axis going through the centerline of the lens tube but not moving around, we put a filling frame as shown in the figure above for stabilization.

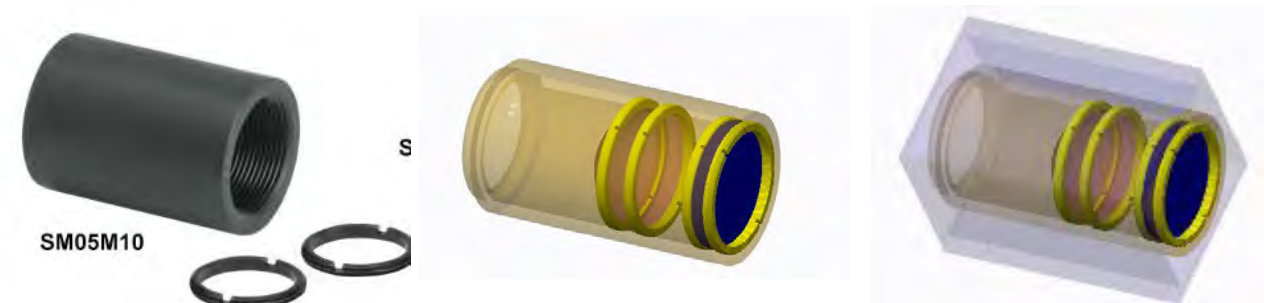

### *Lightguide Coupling*

The lightguide is glued inside the coupler. The hole drilled in the coupler suits perfectly according to the size of the lightguide end. Again, the coupler and the outerprobe piece are also connected by four screws on all sides.

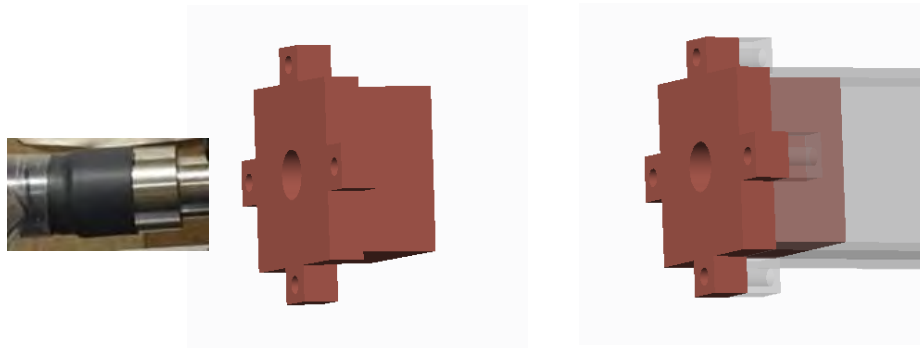

One thing to note during the process of gluing the lightguide to the coupler is that the orientation of the lightguide in the xy-plane is essential to the whole project. Since the lightguide used in this prototype isn't perfect, two or three spots are generated at the other end of the lightguide instead of a single dot. When these dots go through the beam diffuser, they will each form a line pattern at the output, as in configuration 1. We need to orient the lightguide correctly so that all the line forming are overlapping, at the same of making sure energy are not spread out, as shown in configuration 2.

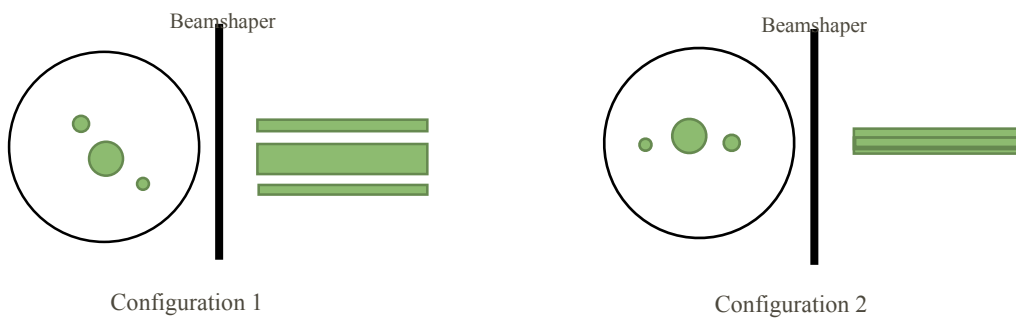

### *LightTools Model using CAD model*

The LightTools Models are shown as below:

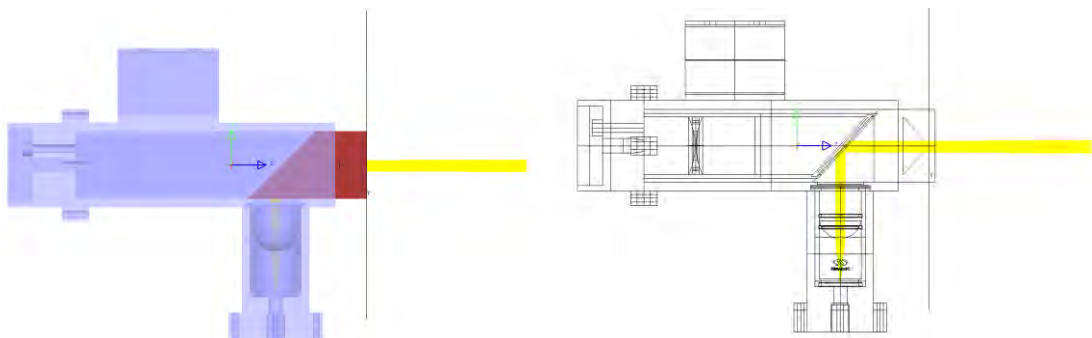

The figure on the left is the translucent model of the probe. The beam diffuser is not included in the model and a circular beam is simulated in the model. A red block inside the probe has the same index

of refraction as water. As we can see, water has nearly no impact on the beam. The figure on the right is the wireframe model of the probe.

## 3D Printing Plan

---

To begin the process of fabricating the imaging probe, we talked in Jim Alkins in the Rettner fabrication shop. We have decided to 3D print four separate parts that will make up the probe. The first printed part will act as a housing structure for most of our components. The second printed part will house the optical reflector, acoustic lens system, and acoustic transducer. These elements will all be immersed in water in order to maximize the ultrasound transmission through the system and therefore this part must be 3D printed with an outer gloss, which will create a water-tight seal. The end of this part will be cut at 45 degrees in order to ensure that the optical reflector remains at the proper angle, as it will simply be placed over this cut out opening. This part will also be fabricated to be slightly smaller than the printed part described before, such that it can be slid in and out of the system. The third printed part will contain a collimating optic and subsequent linear beam shaper, which will collimate and reshape the incident laser beam, exiting from the attached lightguide. The optic and the beam shaper present in this part will remain in air. The fourth part will be a specially designed cap that will be attached to the lightguide and will connect the lightguide to the part described above. Both pieces will be inserted into the first part, which acts as the overall housing for the probe components.

Our customer referred our group to the company 3D Systems that specializes in producing 3D printed parts. They have previously been involved in fabricating 3D probes for our customer and will be able to accommodate our design as well as make it waterproof, through the use of a layer of gloss. This method is expensive, due to the complexity and size of our parts. However, 3D Systems allows us to have our part printed with a high resolution printing material (High-Resolution ABS-like material) and allows us to make the 3D printed probe waterproof. Therefore, although this method is more expensive, it will allow us to produce a more effective probe.

# Test Plan

---

## Overview

The test plan consisted of three stages:

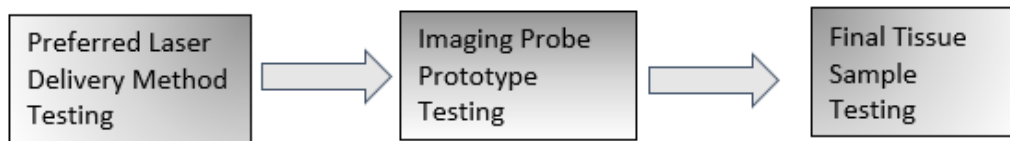

## Detailed Test Plans

### Testing Laser Delivery Proof of Concepts

- 1.) Find the most efficient method for delivering laser light to the 3D printed probe
  - Results:
    - The articulated beam arm is not compatible with our customer's laser, as the beam diverges too fast, leading to the beam hitting the side of the articulated beam arm, prior to exiting the beam arm. This means that very little power was transmitted through the beam arm (as the test results show). However, while the lightguide transmits only about 50% of the incident light, it transmits this amount of light consistently. In addition, it is very flexible and easy to use and is easily attached to the 3D printed probe. Therefore the lightguide offers our team the best way to deliver laser light to the 3D printed probe.
- 2.) Find the most efficient method for coupling the laser to the lightguide and the lightguide to the imaging probe.
  - Results:
    - The optimal coupling method for coupling the laser to the lightguide was to place two optics, one with a 156 mm focal length, and one with a -100 mm focal length. This allowed our team to convert the initial 8 mm diameter laser beam to a beam with a diameter of about 5 mm upon entering the lightguide. This significantly reduced the power loss originating from the mismatch between the initial laser beam diameter and the diameter of the lightguide face.
    - The optimal method for coupling the lightguide to the probe was determined to be the insertion of a collimating optic into the path of the laser, therefore collimating the laser beam entering the beam shaper and decreasing the amount that the laser diverges before it encounters the reflector within the probe. This decreases power loss through the system and makes the system less sensitive to movement of the lightguide. If the beam diverges slower

through the system and the lightguide happens to be moved, the laser incident on the reflector will not change enough to affect our final images.

### Testing of Reflectance of Optical Reflector

- 1.) In order to optimize the outputted power and uniformity of the laser beam, our team constructed multiple optical reflectors. These reflectors are as follows: a 36 mm x 48 mm x 0.52 mm piece of TPX plastic covered with a 1-2 mm thick piece of Aluminum coated Mylar film, a 36 mm x 48 mm x 0.52 mm piece of TPX plastic coated with a thin film of Aluminum, and a 36 mm x 48 mm x 3 mm piece of acrylic mirror. Our team was able to test each reflector to determine the spectral reflectivity of each over the 760-970 nm spectrum. These results are presented in the “Testing Results” section of this document.

Based on the results presented in the next section, the reflector with the best spectral reflectivity was determined to be the piece of TPX plastic covered with a piece of Aluminum coated Mylar film. This reflector was found to have the highest overall spectral reflectivity and produced the brightest and most uniform beam out of the three reflectors.

### Whole System Test

- 2.) Our team was able to effectively test the shape and uniformity of the laser beam outputted from the setup shown below. Here the laser is coupled to the lightguide, which is coupled to the collimating optics inside the lens tube. The laser is then passed through the beam diffuser, also inside the lens tube, and is reflected by the reflector (mylar, aluminum, or acrylic) onto the piece of paper. The results of these tests are shown below, in the “Reflector Results” Section. The best reflector for both spectral reflectivity and beam uniformity was found to be the piece of TPX plastic covered with an Aluminum coated Mylar film.





# Laser Delivery Testing Results

## Beam Arm Method

Testing with HeNe and Infrared Laser

	wavelength(nm)	Start Power(kW)	After mirror (kW)	Output Power(kW)	Loss (%)
Beam Arm + Mirror	632.8	8.23	5.88	4.25	48.36%
	1520	2.18	1.81	0.56	74.34%

Testing with Tunable Nd:YAG pumped-Laser System (customer laser)

	wavelength(nm)	Start Power(kW)	After lightguide(kW)	Output Power(kW)	Loss (%)
Beam Arm	1000	10.2	NA	.397	96.12%
Beam Arm + Lightguide	760	15.0	7.33	.197	98.69%
	1000	15.0	3.00	.167	98.89%

## Lightguide Method

Testing with Tunable Nd:YAG pumped -Laser System (customer laser)

	wavelength(nm)	Start Power(kW)	After lightguide(kW)	Loss (%)
Lightguide	760	15	7.33	51.20%
	1000	15	3.00	80.00%

## Lightguide without Resizing Optics Method

Testing with Tunable Nd:YAG pumped-Laser System (customer laser)

	wavelength(nm)	Start Power(kW)	After lightguide(kW)	Loss (%)
Lightguide	760	10.96	3.60	67.11%
	800	8.59	1.56	81.77%
	850	7.14	1.83	78.59%
	930	8.89	2.87	73.33%
	970	6.30	1.82	81.11%



## Lightguide with Resizing Optics Method

Testing with Tunable Nd:YAG pumped-Laser System (customer laser)

	wavelength(nm)	Start Power(kW)	After lightguide(kW)	Loss (%)
Collimating Optics+ lightguide	760	14.2	7.41	47.69%
	800	13.7	6.95	49.12%
	850	13.3	6.18	53.36%
	930	8.26	4.04	51.11%
	970	12.3	5.98	51.48%

## Lightguide with Coupling Method and Beam Diffuser

Testing with Nd:YAG pumped- Laser (customer laser)

	wavelength(nm)	Power Out of Laser(kW)	Power After lightguide(kW)	Power Through Diffuser (kW)	Loss (%)
Coupling + Lightguide + Beam Diffuser	1000	10.3	3	2.71	73.78%

## Lightguide with Coupling Method, Beam Diffuser, and Partially Opaque TPX

Testing with Nd:YAG pumped- Laser (customer laser)

	wavelength(nm)	Power Out of Laser(kW)	Power After lightguide(kW)	Power Through Diffuser (kW)	Power Through TPX (kW)	Loss (%)
Coupling + Lightguide + Beam Diffuser + TPX	1000	10.3	3	2.71	1.83	82.3%

## Reflector Test Results

---

In deciding what reflector was to be used in our prototype design, our team had to consider two important properties that the reflector had to possess. First, the reflector to be used had to have a high reflectance of laser light in the visible to near-infrared spectrum. This is extremely important as laser light will be pulsed through the probe from 760nm to 970nm and will need to be reflected to the thyroid tissue. The reflected laser light will ideally be in the form of a uniform line such that it can be properly mapped to our detector. The reflector to be used also had to have an acoustic impedance matching water such that a high transmittance of ultrasound signal could be achieved. Our probe will be filled with water during use, explaining why the impedance of the reflector material needs to match that of water. After thorough research of different materials and their properties, three different reflector options were measured with the customer's laser in order to test their reflectance properties. The reflectors constructed were: a 0.52 mm thick piece of TPX plastic covered with a piece of Aluminum coated Mylar film, a 0.52 mm thick piece of TPX plastic coated with a thin Aluminum film, and a 3 mm thick piece of acrylic mirror.

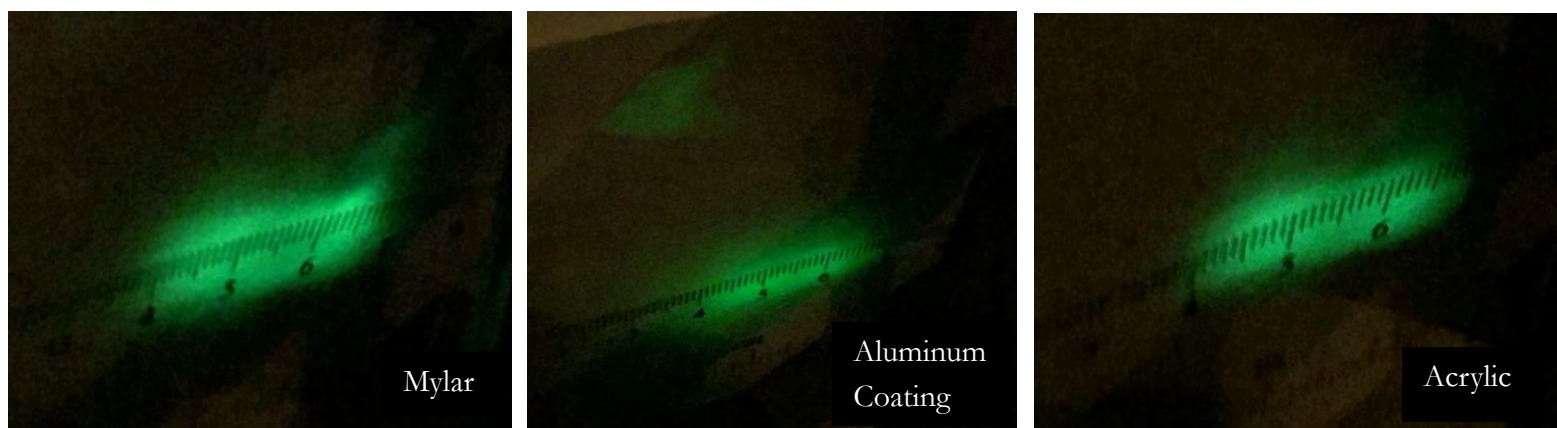

*Outputted laser beam from the optical reflector. Notice that the Mylar produces the brightest spot, while the Aluminum coating produces the dimmest spot. This might have been a result of the non-uniform surface to which the Aluminum coating was applied.*

### Aluminum/Mylar Film on TPX

This first reflector option has a Mylar film that is coated with a thin layer of aluminum. This Mylar film was used as it is known to have great reflectance properties for the range of light our team is interested in using. This Mylar film was put onto a piece of TPX plastic in order to maximize the transmittance of ultrasound signal through the reflector. TPX was used in this scenario as it has an acoustic impedance of 1.84 MRayls while water has an acoustic impedance of 1.5 MRayls. Due to the acoustic impedances being very close, this will help maximize the amount of ultrasound signal that can be transmitted through the reflector. The Mylar film on top of the TPX does not affect the

transmittance of ultrasound waves to a significant degree. The results from our testing as well as an image of the beam after reflection can be seen below.

### Aluminum Coated TPX

The second reflector option tested was a piece of TPX plastic coated with a thin layer of aluminum. TPX was again chosen to help maximize the transmittance of ultrasound signal through the reflector. Aluminum coatings are also used for reflectance coatings in the visible range, so our team was interested in seeing how a coating of this type would react with our laser. The results from our testing as well as an image of the beam after reflection can be seen below.

### Acrylic

The third reflector option tested was an FABBACK Acrylic Mirror obtained from the company Plaskolite. Acrylic was used as an option for our reflector as it is a much easier plastic to coat than TPX so more options were available to our team. However, acrylic has a much higher acoustic impedance than TPX (3-3.15 MRays). Therefore, it is more difficult to match the acoustic impedance of acrylic to the acoustic impedance of water. Compared to the TPX plastic, acrylic will not transmit nearly as much ultrasound signal. However, due to the theorized great reflectance properties, our team felt this was a reflector worth testing. The results from our testing as well as an image of the beam after reflection can be seen.

### Reflectance for Optical Reflector

Aluminum/Mylar Film on TPX

	wavelength(nm)	Power Out of Lightguide (kW/pulse)	Power Reflected Off of Reflector (kW/pulse)	Loss (%)
	760	1.50	1.23	18%
	800	1.50	0.93	38%
	850	1.50	0.58	61%
	930	1.50	0.43	71%
	970	1.50	0.70	53%

### Aluminum – Coated TPX

	wavelength(nm)	Power Out of Lightguide (kW/pulse)	Power Reflected Off of Reflector (kW/pulse)	Loss (%)
	760	1.50	0.87	42%
	800	1.50	0.67	55%
	850	1.50	0.43	71%
	930	1.50	0.35	77%
	970	1.50	0.67	55%

### Acrylic

	wavelength(nm)	Power Out of Lightguide (kW/pulse)	Power Reflected Off of Reflector (kW/pulse)	Loss (%)
	760	1.50	1	33%
	800	1.50	0.7	53%
	850	1.50	0.66	56%
	930	1.50	0.23	85%
	970	1.50	0.57	62%

## Timeline

	wavelength(nm)
January	<ul style="list-style-type: none"> <li>• Month of testing possible laser delivery systems on customer's laser               <ul style="list-style-type: none"> <li>○ Need to find system most effective at minimizing power loss</li> </ul> </li> <li>• Investigate possible geometries of imaging probe               <ul style="list-style-type: none"> <li>○ Draft imaging probe CAD model</li> </ul> </li> </ul>
February	<ul style="list-style-type: none"> <li>• Test Beamsplitter/Mirror Delivery Method (last method to test)</li> <li>• Finalize general design of laser delivery system               <ul style="list-style-type: none"> <li>○ Draft CAD model of delivery system</li> <li>○ Construct CAD model for imaging probe</li> </ul> </li> <li>• Begin building first working prototype of delivery system</li> <li>• Finalize final geometry of imaging probe</li> <li>• Investigate material options for reflector</li> <li>• Order/gather final materials</li> </ul>
March	<ul style="list-style-type: none"> <li>• Testing of delivery system prototype with customer's laser</li> <li>• Investigate methods of coupling laser to delivery system</li> <li>• Construct final CAD model of delivery system</li> <li>• Construct the imaging probe and test laser delivery through probe</li> <li>• Investigate ways of coupling the imaging probe to the laser delivery system</li> </ul>
April	<ul style="list-style-type: none"> <li>• Couple laser to deliver system; couple delivery system to imaging probe               <ul style="list-style-type: none"> <li>○ Investigate ways of coupling the imaging probe to the laser delivery system</li> </ul> </li> <li>• Final testing of laser delivery system with a real slice of thyroid tissue</li> <li>• Making sure correct alignment is in place</li> <li>• Power loss effectively minimized and meet specifications</li> </ul>

## Risk Assessment

---

The main issues of our system arise from the fact that it will primarily be used on live patients. Tolerances of the system have to be closely adhered to such that the risk of system performance failure is minimized. Not adhering properly to system constraints could cause a risk in laser performance, possibly causing the laser to burn the patient or damage body tissue. Any change in parameters of the system from factors such as extended use to damage could cause more than 20 mJ/pulse to be delivered to the patient which is against ANSI standards. It is also important to take into account that if the laser were to start burning body tissue, smoke arising from this process could cause various viruses to come about within the patient.

## Recommendations

---

Throughout the design process of this project, our team did not have the proper amount of time or the budget to be able to pursue all options available to us in the design of our imaging probe. Outlined below are a few recommendations that a future team can use as a guideline to explore ways in which this prototype can be improved.

**Recommendation 1:** The collimating optic used in our design is a single NBK7 Plano-convex lens. This optic was decided upon through the use of testing with a shear plate. A single element was used in order to try and collimate our laser beam as best as possible while trying to not make the system any longer in length. However, it was found at the end of our design process that this doesn't effectively collimate the beam as well as we thought. A possible option to explore could be the use of a two lens beam expander to collimate the incoming beam. This will make the system a bit longer in length, however, it has the chance to collimate our beam to a more extreme degree. This could improve the system by further preventing divergence of the beam throughout the system.

**Recommendation 2:** As discussed above, the reflector that performs the best optically was the TPX plastic, covered with an Aluminum coated Mylar film. Acoustically, the TPX is very similar in acoustic impedance to water and therefore would produce very little acoustic reflection when imaging and is thin enough (0.52 mm thick) not to be a strong attenuator of the acoustic signal. Therefore, the TPX reflector would be ideal both optically and acoustically. However, the reflector our team produced for this project is not stable enough, mechanically, to be used clinically; it functions better as a proof of concept piece. Given that the TPX is the preferred material for acoustic signal transmission, the ideal reflector would be a thin piece of TPX (0.5-1 mm) that would be coated with a highly reflective (~99%) coating that peaks in the visible to near infrared spectral region (possibly gold). This part may be expensive and hard to make (long lead time). However, it would serve as the optimal reflector for this probe.

**Recommendation 3:** The Edmund Optics lightguide that is currently being used to deliver laser light to the 3D printed probe is not the ideal laser delivery system. Without a system of optics in place to focus the laser into the face of the lightguide, it results in high power loss ( $\Rightarrow$ 50%); if this system is not aligned correctly, the power loss can be even greater. Therefore the ideal laser delivery system would be a system in which there is low power loss, low spectral sensitivity, and is highly flexible. One proposed system has been mentioned already: the use of beamsplitters to split the beam into multiple multimode fibers initially and recombine the light exiting the fibers, prior to entering into the 3D printed probe. This would allow for a high amount of flexibility, low power loss if aligned properly, and would allow for low spectral sensitivity, if the fibers are chosen correctly. The main downside to this option is the high sensitivity to alignment and difficulty in focusing multiple beams into small, multimode fibers. It also may not be stable enough to transport or employ as a clinical tool.

## Future Plans

---

At the end of this current semester (Spring 2016), our team will deliver a working prototype for the photo-acoustic imaging probe to our customer based on the culmination of our research over this past year. Our customer will use this in-vivo prototype to gather images of malignant and benign thyroid tissue for comparison. This first prototype will be used to set a baseline standard for the quality of images that can be taken using a device of this nature. Future senior design teams may work with our customer to change different specifications of our prototype in order to improve the system. The laser delivery system as well as reflector choice can be changed in order to maximize the power of the laser travelling through the system as well as maximize the transmittance of ultrasound signal. Through further study, future teams may also work with our customer to develop an imaging probe that is able to produce images of better quality. This next prototype built can be compared to the baseline set by the first prototype our team has designed. Future work will mostly revolve around improving our initial design to a point where it can be put through clinical trials for eventual use in the medical field.

# Appendix

## Appendix A:

Specification Sheet for Edmund Optics 4 foot Flexible Fiber Optic Light Guide:

### Flexible Fiber Optic Light Guide, Stock No. #39-367

Acceptance Angle (°)	68
Diameter (mm)	6.35
Length (cm)	121.92
Fiber Diameter (μm)	50
Fiber Bundle Dimensions (mm)	LENGTH A: 7.92 B: 10.72 C: 14.22 D: 10.41
Numerical Aperture NA	0.55
Index of Refraction $n_d$ - Core	1.581
Index of Refraction $n_d$ - Cladding	1.487
Packing Fraction (%)	82% nominal
Operating Temperature (°C)	-40 to +107
Compatible Light Guide Adapter	SX: #38-944 MX: #66-905
Minimum Bend Radius (mm)	38.1
Type of Illumination	Fiber Optic Light Guide
Geometry	Spot Light
Power Loss (%/foot)	6%

Specification Sheet for Newport 2 inch Lens Tube:



The LT10-20 Lens Tube provides a means to mount multiple lenses into a single holder. The 2 inch (50.8 mm) long lens tube has an internal thread on one end and a mating external thread on the other. This allows them to be connected together end-to-end to provide endless configurations. 1 inch (25.4 mm) diameter lenses are held in place with threaded retaining rings and one ring is included with each lens tube.

<b>Model</b>	LT10-20
<b>Type</b>	Lens Tube
<b>Optic Size Held</b>	1.0 in. ( 25.4 mm)
<b>Thread Type</b>	1.035-40
<b>Diameter</b>	1.0 in. ( 25.4 mm)
<b>Length</b>	2.0 in. ( 50.8 mm)

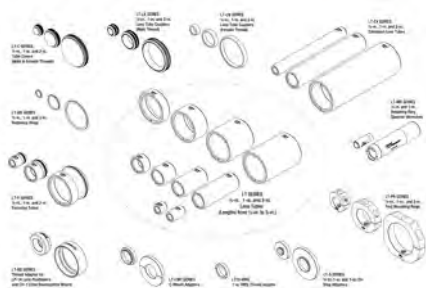

Specification Sheet for ThorLabs 1 inch, 25.4 mm focal length, Plano-Convex Lens:

### LA1951-A - N-BK7 Plano-Convex Lens, Ø1", f = 25.4 mm, AR Coating: 350-700 nm



**Part Number:** LA1951-A - [Ask a technical question](#)  
**Package Weight:** 0.07 lbs / Each  
**Available / Ships:** Today  
**RoHS:**  
**Price:** **\$33.40**  
**Add To Cart:** Qty:    
**Release Date:** Sep 7, 2000

Specification Sheet for RPC Photonics Engineered Diffuser EDL-4 Model:

Engineered Diffusers™

EDL-4-07234

Scatter Properties	
Model	EDL-4-07234-A
Shape	1D Line
Divergence angle	3.8°
Physical Properties	
Material	Polymer-on-glass
Index of refraction	1.56 @ 633nm
Clear aperture	Center 95%
Transmission spectrum	400-2000nm
Temperature range	-50°C to 120°C
Damage threshold	20J/cm <sup>2</sup>

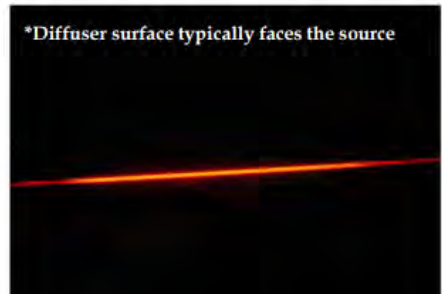
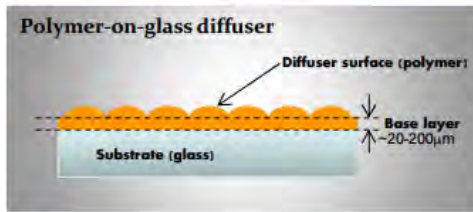

Specification Sheet for Newport 1 inch Diameter Retaining Rings:

The LT10-RR Retaining Ring is used for 1 inch LT Series lens tubes

<b>Model</b>	<b>LT10-RR</b>
<b>Type</b>	Lens Tube
<b>Thread Type</b>	1.035-40
<b>Diameter</b>	1.0 in. ( 25.4 mm)

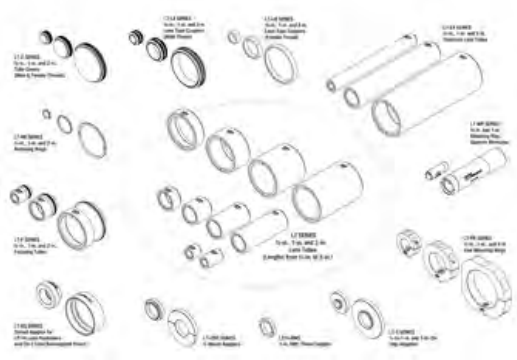

## Appendix B:

### Beam Resizing Optics CodeV Lens Listing:

```
;lis;go
  Beam refocusing lens
      RDY          THI      RMD      GLA          CCY  THC  GLC
OBJ:      INFINITY      INFINITY
STO:      INFINITY      20.000000
  2:      160.68000      8.000000      NBK7_SCHOTT      0  0
      SLB: "positive"
  3:      -160.68000      56.000000      PIK      0
  4:      -103.00000      5.000000      NBK7_SCHOTT      0  0
      SLB: "negative"
>  5:      103.00000      65.000000      PIK      100
  6:      INFINITY      0.000000      100      100
IMG:      INFINITY      0.000000      100      100
```

#### SPECIFICATION DATA

```
EPD      8.00000
AFI      10.00000
DIM      MM
WL      970.00  930.00  850.00  760.00
REF      2
WTW      1      1      1      1
INI      ZX
XAN      0.00000
YAN      0.00000
WTF      1.00000
VUY      0.00000
VLY      0.00000
POL      N
```

#### APERTURE DATA/EDGE DEFINITIONS

```
CA
CIR S2      25.000000  ! [A1]
CIR S3      25.000000  ! [A1]
CIR S4      25.000000  ! [A1]
CIR S5      25.000000  ! [A1]
CIR S7      25.000000  ! [A1]
```

#### REFRACTIVE INDICES

```
GLASS CODE      970.00      930.00      850.00      760.00
NBK7_SCHOTT      1.507929      1.508526      1.509840      1.511613
```

No solves defined in system

#### PICKUPS

```
PIK RDY S3 Z1 RDY S2 Z1 -1.000000
PIK RDY S5 Z1 RDY S4 Z1 -1.000000
```

INFINITE CONJUGATES

EFL	16.2260
BFL	9.9853
FFL	267.6454
FNO	2.0283
IMG DIS	0.0000
OAL	154.0000
PARAXIAL IMAGE	
HT	0.0000
ANG	0.0000
ENTRANCE PUPIL	
DIA	8.0000
THI	0.0000
EXIT PUPIL	
DIA	0.4850
THI	10.9690

Appendix C:

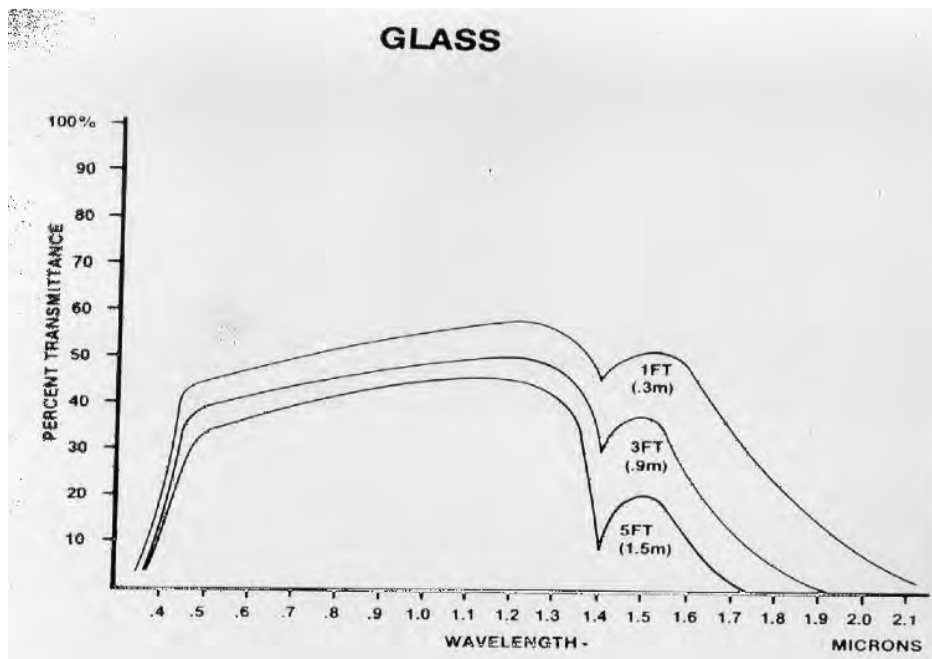

*Plot of the spectral transmittance for various sizes of Edmund Optics Flexible Fiber Optic Light Guides*

The lightguide that our team chose to use is about four feet in length and therefore would display a transmittance profile between that of the three foot lightguide and the five foot lightguide. The transmittance for a four foot lightguide, as given above, would range from about 40% to about 42 or 43 % and therefore would be much lower than the transmittance values that we measured in our customer's lab. This is most likely a result of the increased laser input into the lightguide, due to the implementation of the two lens coupling system. As shown, while wavelength does influence the output of the lightguide, it does not significantly affect the transmission of light, particularly not in a

way that would affect the final images produced by the probe. As such, spectral dependence is not a concern for our team's chosen method of laser delivery.

## Appendix D:

Specification Sheet for EKSPLA Nd:YAG Pumped, OPO Laser:

<b>OPO specifications sheet<sup>1)</sup></b>				
<b>Model</b>	<b>NT341A</b>	<b>NT341B</b>	<b>NT342A</b>	<b>NT342B</b>
<b>OPO</b>				
Wavelength range, nm: <sup>2)</sup>				
Signal	420-680	420-680	420-709 <sup>3)</sup>	420-709 <sup>3)</sup>
Idler	740-2300	740-2300	710-2300 <sup>3)</sup>	710-2300 <sup>3)</sup>
SH generator (optional)	-	-	210-419	210-419
SH/SF generator (optional)	-	-	225-419	225-419
DUV generator (optional)	-	-	-	193-210
Output pulse energy, mJ				
OPO <sup>4)</sup>	20	40	15	30
SH generator (optional) <sup>5)</sup>	-	-	2	4
SH/SF generator (optional) <sup>6)</sup>	-	-	3	6
DUV generator (optional) <sup>7)</sup>	-	-	-	1
Linewidth, cm <sup>-1</sup> <sup>8)</sup>	10-350	10-350	<5	<5
Scanning step, nm:				
Signal (420-709 nm)	0.1	0.1	0.1	0.1
Idler (710-2300 nm)	1	1	1	1
SH range (210-419 nm)	-	-	0.05	0.05
Pulse duration, ns <sup>9)</sup>			3-5	
Typical beam diameter, mm <sup>10)</sup>	4	5	4	5
Typical beam divergence, mrad <sup>11)</sup>	<6	<6	<2	<2
Polarization:				
Signal beam	horizontal	horizontal	horizontal	horizontal
Idler beam	horizontal	horizontal	vertical	vertical
SH/SF beam	-	-	vertical	vertical
<b>Pump laser <sup>12)</sup></b>				
Pump wavelength, nm	355			
Max pump pulse energy, mJ	70	135	70	135
Pulse duration, ns	4-6			
Beam quality	*Hat-Top* in near and near Gaussian in far fields			
Beam divergence, mrad	<0.5			
Pulse energy stability (Std.Dev), %	<3.5			

---

# In-vivo Thyroid Photoacoustic Camera Product Requirements Document “Beam Squad”

Zhenzhi Xia (Project Coordinator)

Tim Ehmann (Customer Relationship)

Jordan Teich (Document)

Guanyao Wang (Scribe)

---

Document Number 004

Revisions Level: E

Date: 11 December 2015

This is a computer-generated document. The electronic master is the official revision. Paper copies are for reference only. Paper copies may be authenticated for specifically stated purposes in the authentication block.

Authentication Block
----------------------

## Revision History

<b>Rev</b>	<b>Description</b>	<b>Date</b>	<b>Authorization</b>
A	Release	November 2 2015	All
B	Added timeline Laser delivery requirements Updated responsibility	November 15 2015	T, Z
C	Updated fitness for use, desirables Added budget/materials Added specifications Updated timeline	November 22 2015	All
D	Added group responsibilities Added proposed laser delivery systems Updated budget/materials Added recourses needed Added appendix	December 09 2015	All
E	Updated divergence spec Updated focusing lens spec and price Updated resources needed (lens design)	December 11 2015	All



## Table of Contents

<b>REVISION HISTORY</b> .....	<b>45</b>
<b>TABLE OF CONTENTS</b> .....	<b>46</b>
<b>1. INTRODUCTION</b> .....	<b>48</b>
VISION.....	48
<b>2. ENVIRONMENT</b> .....	<b>49</b>
TEMPERATURE .....	49
HUMIDITY .....	49
<b>3. LASER SAFETY ISSUES</b> .....	<b>49</b>
<b>4. FITNESS FOR USE</b> .....	<b>50</b>
4.1 FITNESS FOR USE .....	50
4.2 SPECIFICATIONS.....	50
4.3 DESIRABLES .....	51
<b>5. GROUP RESPONSIBILITIES</b> .....	<b>51</b>
5.1 WE ARE RESPONSIBLE FOR .....	51
5.2 WE ARE NOT RESPONDIBLE FOR .....	51
<b>6. PROPOSED LASER DELIVERY SYSTEMS</b> .....	<b>52</b>
6.1 ARTICULATED BEAM ARM METHOD .....	52
6.2 LIGHTGUIDE METHOD .....	53

6.3 BEAMSPLITTER METHOD .....	54
7. MATERIALS .....	55
8. RESOURCES NEEDED.....	56
9. TIMELINE.....	57
APPENDICES AND REFERENCES.....	58

## 1. Introduction

The in-vivo photoacoustic camera currently being researched has the potential to be a tool used in detecting early stage thyroid cancer. The camera is being developed under the supervision and with the help of Dr. Navalgund Rao, a professor in the Imaging Sciences Department at RIT, Dr. Vikram Dogra, a doctor in the Radiology Department at the University of Rochester Medical Center (URMC), and Dr. Bhargava Chinni, a researcher in the Department of Imaging Sciences at URMC. The goal of this project is to ultimately create a laser delivery system which will deliver laser light to a handheld probe. If time permits, this probe will also be designed and fabricated.

### Vision

---

An in-vivo photo-acoustic thyroid imaging system for use in a clinical setting, with the purpose of differentiating between normal and malignant tissue within the thyroid. This consists of a laser source, laser delivery system, an imaging probe, and a detector within the probe. The primary goal of this project is to design the laser delivery system which connects to the imaging probe placed against the patient's neck. This delivery system must have low power loss and must produce a uniform beam, as the source of illumination for the imaging probe.

## 2. Environment

As a

laboratory instrument, it needs to operate in the following environment:

### Temperature

15-35 °C - safe operation/ meets specifications

### Relative Humidity

Non-condensing – meets specifications and safe operation

- Acoustic lens **5** must be able to be submerged in water or a similar liquid.
- The liquid used in the setup should have matching acoustic impedance to the reflecting plate **4**.
- During normal operation, the imaging probe **3** will come into contact with human tissue **8**. Therefore any parts of the probe in contact with human tissue must be readily cleaned and sterilized. Also, the probe must be sealed from outside fluids and gases.
- Wall power is necessary for the laser that is used as the source. The laser which acts as the source for the camera, will be too large to be portable and as such, must be located on a tabletop, far enough away as not to impede the physician.
- The probe **3** itself must be handheld and easily portable.
- The images produced by the imaging probe must be displayed in real time on a computer monitor, connected to the probe.

## 3. Laser Safety Issues

- The laser proposed for use in this product is characterized as a class four laser.
- The laser used in this camera falls under ANSI standard Z 136.1 specifying that the peak power of the laser pulses incident upon tissue must be less than  $20 \text{ mJ/cm}^2$ .

## 4. Fitness for Use

### 4.1 Fitness for Use:

Our group is responsible for the laser delivery system that delivers the source illumination (laser light) to an imaging probe **3**, similar to that which has been created already for an in vitro application. As such, the delivery system will:

- Be able to move in three dimensions
- Produce a uniform beam (uniformity metric is still being discussed)
- Result in power loss <50%

4.2 Specifications		
Laser Source		
Wavelength	=	700-1200nm; specifically 760, 850, 930, and 970 nm
Pulse Repetition Frequency	=	1-10 Hz
Pulse Duration	=	3-5 ns
Pulse Peak Power	=	10-70 mJ/cm <sup>2</sup>
Beam Diameter	=	8mm
Laser Delivery System		
Power Loss	<	50% over 700-1200 nm bandwidth
Divergence	<	0.5 mrad
Uniformity of output beam	>	90%
Movement	=	Able to move in x,y,z directions
Detector		
Transducer array	=	32 element, linear array
Pitch	=	0.3 mm
Element Dimensions	=	0.7 x 1 x 0.15 mm
Center Frequency	=	8 MHz

### 4.3 Desirables

Our group is responsible for designing the laser delivery system that will deliver laser light to an imaging probe. If time permits, we will also proceed with creating said imaging probe according to our customer. It is desirable that the entire system:

- Be able to image one lobe of the thyroid using a handheld, portable probe **3**
- Have a resolution of 0.7x1.0x0.15 mm, based on the size of the detector elements **6**.
- Produce images through the use of inexpensive real time focusing with C-scan image display on the detector.
- Contain a beam shaping diffuser **7** that can convert a circularly or linearly shaped beam to a linear distribution **8** such that the beam matches the dimensions of the linear array transducer **6**.
- Contain either a thin glass plate **4**, which acts as an acoustic reflector, or a plate composed of an acoustically transmissible material, coated with an optically reflective coating.

Using proposed delivering system with beam arm, the system may also:

- Include a coupling system **1** from laser source to the delivery system, as well as from the delivery system to the probe.

## 5. Group Responsibilities

### 5.1 We Are Responsible For:

- Designing a laser delivery system for a multi-mode infrared laser that will be the most efficient at minimizing power loss
- Design the laser delivery system such that it delivers pulses at or under 20 mJ/cm<sup>2</sup> in order to meet ANSI standards
- Building and testing a prototype with the customer's laser system to make sure the delivery system is up to the customer's expectations

### 5.2 We Are Not Responsible For:

- Designing and creating a prototype of the imaging probe
- Finding a method in which to couple the imaging probe to our laser delivery system
- Integrating the software that will be used to analyze images of thyroid tissue with the entire system
- Any finite element analysis involving the transmission rate of ultrasound through the imaging probe

## 6. Proposed Laser Delivery Systems

### 6.1 Articulated Beam Arm Method

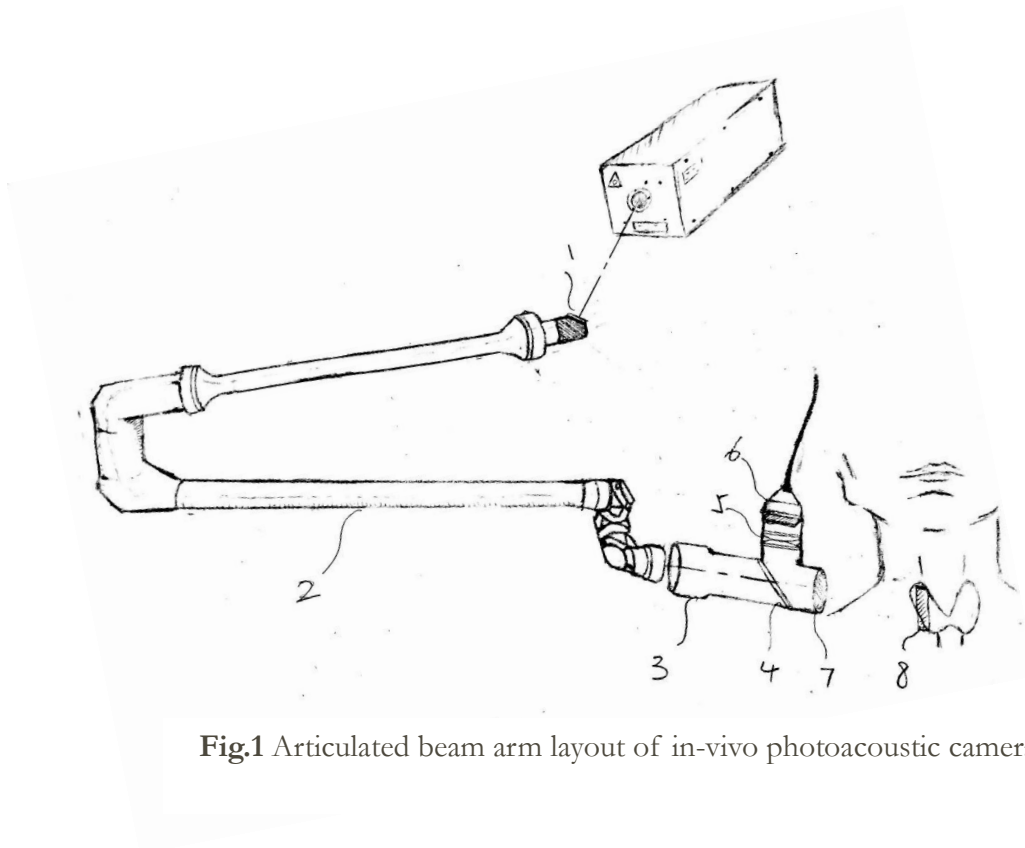

**Fig.1** Articulated beam arm layout of in-vivo photoacoustic camera

Main Requirements and Specifications	
<ul style="list-style-type: none"> <li>• Piping that can withstand high power laser</li> <li>• AR coated prisms or mirrors coated to be ~99% reflective</li> <li>• Translational system for movement in three dimensions</li> </ul>	
Advantages	Disadvantages
<ul style="list-style-type: none"> <li>• Low power loss</li> <li>• Performance related to wavelength and power of incident laser beam related to the prisms or mirrors located inside of the beam arm</li> <li>• (These prisms and mirrors can be easily selected to match our specifications)</li> </ul>	<ul style="list-style-type: none"> <li>• A simple mechanical design may be clunky and unwieldy, while a more complex mechanical design, allowing for fluid movement in three dimensions, would be time consuming</li> <li>• Difficult to ensure proper alignment of mirrors</li> </ul>



## 6.2 Lightguide Method

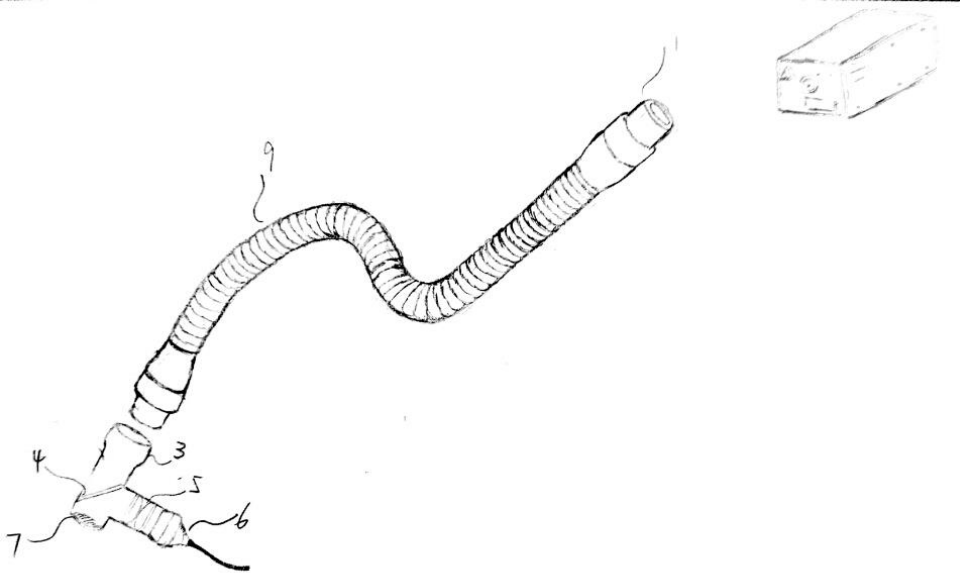

Fig.2 Lightguide layout of in-vivo photoacoustic camera

Main Requirements and Specifications	
<ul style="list-style-type: none"> <li>• Lightguide, usable in the Visible-IR spectrum (see <b>Appendix.C</b>)</li> <li>• (Currently exploring the possibility of using a 6.35 mm diameter, 1.22 m long lightguide provided by Dr. Rao)</li> </ul>	
Advantages	Disadvantages
<ul style="list-style-type: none"> <li>• Flexible and easy to use</li> <li>• Readily Usable</li> <li>• Will allow us time to design the imaging probe that will be connected to the laser delivery system</li> </ul>	<ul style="list-style-type: none"> <li>• Power loss increases with length of the light guide- must keep the lightguide short (the lightguide is comprised of many smaller optical fibers, whose core sizes are small. Therefore power will be lost upon entering the lightguide as well)</li> <li>• Produces a diffuse laser, rather than the desired, high uniformity laser beam</li> <li>• May not be able to handle high powered pulses- TBD</li> </ul>

### 6.3 Optical Fiber Bundle with Beamsplitters Method

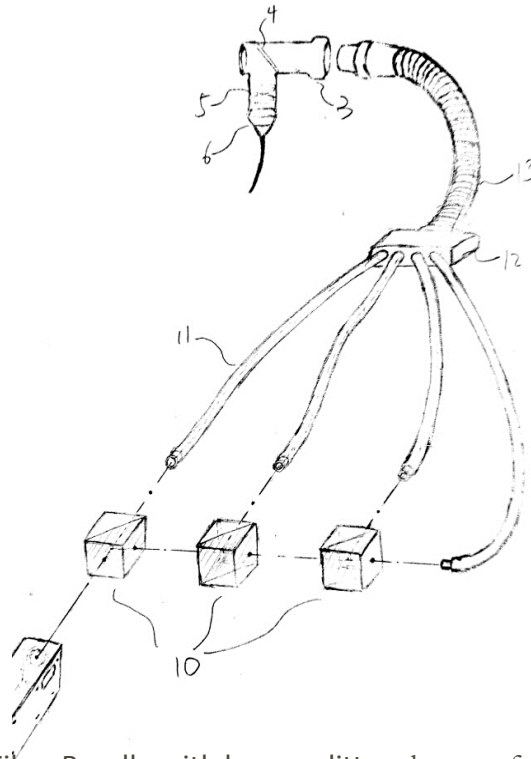

Fig.3 Optical Fiber Bundle with beamsplitters layout of in-vivo photoacoustic camera

Main Requirements and Specifications	
<ul style="list-style-type: none"> <li>• Multiple beamsplitters; this number will vary based on our final design of the system</li> <li>• Multiple lightguides or optical fibers; again, this number will vary depending on the final design of the system and the damage threshold of each fiber or lightguide</li> <li>• Focusing Lenses; depends on the number of fibers or lightguides we plan to use</li> <li>• Box with black coating or paint around the inside, in order to ensure that no laser light reflects off the inside of the box; minimizes stray light escaping from the delivery system</li> </ul>	
Advantages	Disadvantages
<ul style="list-style-type: none"> <li>• By splitting the laser beam into multiple fibers or lightguides, we are able to avoid destroying the fibers or lightguides with pulses <math>\geq 10 \text{ mJ/cm}^2</math></li> <li>• Allows for flexibility of lightguide or fiber optic cable</li> </ul>	<ul style="list-style-type: none"> <li>• Each fiber or lightguide produces power loss; therefore if too many fibers or lightguides are used, the system will approach <math>&gt;50\%</math> power loss</li> <li>• Requires multiple beamsplitters, optical fibers or lightguides; may inflate cost</li> <li>• Efficient coupling of fibers or lightguides to the beamsplitters must be ensured in order to reduce power loss; this makes the system more difficult to design</li> </ul>

## 7. Materials

Our budget has been loosely set at anything less than \$1000. The materials necessary for testing and construction of the laser delivery system are listed below:

Proposed delivery system	Items for construction/testing	Price
Articulated Beam Arm Method (Fig.1)	Piping	May already be available through WHK lab
	Thor Labs 15 mm right angle prism-mirror, with protective silver coating	Each prism is about \$69
	Edmund Optics broadband dielectric coated $\lambda/10$ 15 mm mirror	Each mirror is about \$85
Lightguide Method (Fig.2)	Edmund Optics $\frac{1}{4}$ " diameter, 48" long lightguide	Provided
Optical Fiber Bundle with Beamsplitters Method (Fig.3)	Thor Labs 2 m, 550 $\mu\text{m}$ core diameter high power multimode fiber optic cable	Each cable is about \$191
	Edmund Optics $\frac{1}{4}$ " diameter, 48" long lightguide	Provided
	Multiple Thor Labs 20 mm, 50:50 cube beamsplitters	Each beamsplitter is about \$190
	Multiple Edmund Optics plano-convex, high damage threshold, focusing lenses; 12 mm diameter, 12 mm focal length	Each lens is about \$37

## 8. Resources Needed

The following individuals will be used as advisors for our team:

- Graduate student (provided by WHK) for advising on possible lens designs for our delivery system
- Jim Zavislan for advice on the radiometry of our system
- Dr. Navalgund Rao for general system help

The following software will be used in the design process:

- CODE V for optical design
- CAD for modeling prototypes of the delivery system

## 9. Timeline

By 11/23/15 (PRD Review 2)	<ul style="list-style-type: none"> <li>• Test beam arm setup with HeNe 623.8nm laser and infrared laser (1520nm) <ul style="list-style-type: none"> <li>○ Done in order to test overall power loss through the system</li> </ul> </li> <li>• Begin creation of a Bill of Materials</li> <li>• Research other medical uses of PA imaging to gain additional insight</li> <li>• Obtain beam diffuser from Per to begin testing possible ways to shape our laser beam in the imaging probe</li> </ul>
By 12/4/15	<ul style="list-style-type: none"> <li>• Run tests on possible laser delivery systems <ul style="list-style-type: none"> <li>○ Find spec sheet on Per's lightguide (make sure less than 50% power loss)</li> <li>○ Use customer's laser to test power loss in beam arm system</li> </ul> </li> <li>• Double check specifications of laser theoretically work for this application</li> <li>• Identify areas of confusion in PRD to ask customer before final presentation</li> </ul>
By 12/9/15	<ul style="list-style-type: none"> <li>• Present final Project Review Document in class</li> <li>• Finalize our Bill of Materials</li> <li>• Meet with last year's photo-acoustic team for advice</li> <li>• Create schedule for spring semester in order to test/examine all realistic laser delivery possibilities</li> </ul>
By 12/15/15	<ul style="list-style-type: none"> <li>• Order parts/gather borrowed parts for future assembly</li> <li>• Finalize list of possible/realistic ideas for laser delivery systems</li> </ul>
January	<ul style="list-style-type: none"> <li>• Month of testing possible laser delivery systems on customer's laser <ul style="list-style-type: none"> <li>○ Need to find system most effective at minimizing power loss</li> </ul> </li> <li>• Investigate possible geometries of imaging probe <ul style="list-style-type: none"> <li>○ Draft imaging probe CAD model</li> <li>○ Think of materials to be used for reflector</li> </ul> </li> </ul>
February	<ul style="list-style-type: none"> <li>• Finalize general design of laser delivery system</li> <li>• Draft CAD model of delivery system</li> <li>• Investigate methods of coupling laser to delivery system</li> <li>• Begin building first working prototype of delivery system</li> </ul>
March	<ul style="list-style-type: none"> <li>• Testing of delivery system prototype with customer's laser</li> <li>• Working towards building finalized delivery system</li> <li>• Construct final CAD model of delivery system</li> </ul> <p>If time permits,</p> <ul style="list-style-type: none"> <li>• Construct the imaging probe and test laser delivery through probe</li> <li>• Investigate ways of coupling the imaging probe to the laser delivery system</li> <li>• Construct CAD model for imaging probe</li> </ul>
April	<ul style="list-style-type: none"> <li>• Couple laser to deliver system; if we are able to create the imaging probe, we will try to couple the delivery system to the probe to create final design</li> <li>• Final testing of laser delivery system <ul style="list-style-type: none"> <li>○ Making sure correct alignment is in place</li> <li>○ Power loss effectively minimized</li> </ul> </li> </ul> <p>If we can design and create the imaging probe,</p> <ul style="list-style-type: none"> <li>• Final testing of delivery system coupled with image probe and error checking</li> </ul>

## Appendix

### Appendix A:

This appendix section contains a list of all properties that the overall photo-acoustic thyroid imaging microscope must have that are not directly related to our project. They are very important to keep in mind.

- During normal operation, the imaging probe will come into contact with human tissue and/ or liquids. Therefore any parts of the probe in contact with human tissue must be readily cleaned and sterilized. Also, the probe must be sealed from outside fluids and gases.
- The probe itself must be handheld and easily portable. The laser which acts as the source for the camera, will be too large to be portable and as such, must be located on a tabletop, far enough away as not to impede the physician.
- Wall power is necessary for the laser which is used as the source for the probe. The images produced by the imaging probe must be displayed in real time on a computer monitor, connected to the probe.
- The system be capable of taking a series of sequential images where the transducer automatically increments the axial position of the tissue and stores an image for each of these axial positions.
- For a 20 x 20 mm section of thyroid tissue, have a typical acquisition time of of 2 minutes.
- Produce four consecutive images of the thyroid tissue at wavelengths 760, 850, 930, and 970 nm in order to examine the concentration of oxy-hemoglobin, deoxy-hemoglobin, lipids, and water in thyroid tissue.
- Be able to use these four images to identify areas of oxygenated and deoxygenated hemoglobin using chromophore analysis.
- Contain an inexpensive acoustic lens system, optimized for use in a liquid environment.
- Be able to be moved and operated with a minimum of adjustments.

## Appendix B:

If we are able to design the accompanying imaging probe that is to be attached to the laser delivery system, we will need to purchase or find separate materials. These are listed below:

System Component	Purposes	Price
Imaging Probe Part 3	Items necessary for construction/testing	3D printed; printing plastic ~\$5 per cubic inch
Engineered Diffuser (Beam shaper) 7	Engineered Diffuser from RPC Photonics	Each diffuser, according to the RPC website ranges from \$160 – 250
Ultrasound Reflector 4	Edmund Optics high efficiency, AR coated window	Each window is about \$15
Acoustic Lens 5	3D printing material, possibly PZT	Again, plastic material is ~\$5 per cubic inch

## Appendix C:

The following tables are contain the specifications of the lightguide we are planning to use in the lightguide method (see **Fig.2**) as well as the adapters Edmund suggests to use when coupling to the laser source:

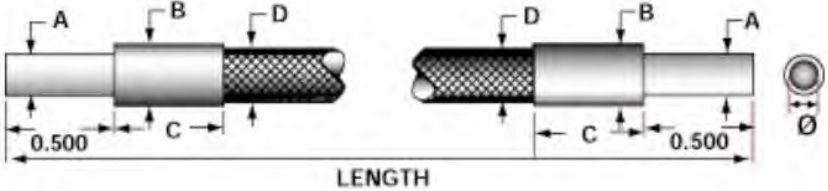

## Flexible Fiber Optic Light Guide, Stock No. #39-367

Acceptance Angle (°)	68
Diameter (mm)	6.35
Length (cm)	121.92
Fiber Diameter (μm)	50
	
Fiber Bundle Dimensions (mm)	A: 7.92 B: 10.72 C: 14.22 D: 10.41
Numerical Aperture NA	0.55
Index of Refraction $n_d$ - Core	1.581
Index of Refraction $n_d$ - Cladding	1.487
Packing Fraction (%)	82% nominal
Operating Temperature (°C)	-40 to +107
Compatible Light Guide Adapter	SX: #38-944 MX: #66-905
Minimum Bend Radius (mm)	38.1
Type of Illumination	Fiber Optic Light Guide
Geometry	Spot Light
RoHS	Not Compliant

### 0.316" ID, Fiber Optic Adapter SX-6, Stock No. #38-944

Model Number	SX-6
Inner Diameter (inches)	0.316
Inner Diameter (mm)	8.03
Outer Diameter (mm)	25
Thickness (mm)	9.5
Construction	6061-T6 Aluminum
Type of Illumination	Accessory
RoHS	Not Compliant

---



### 0.316" ID Fiber Optic Adapter MX-6, Stock No. #66-905

Model Number	MX-6
Inner Diameter (inches)	0.316
Inner Diameter (mm)	8.03
Outer Diameter (mm)	25
Thickness (mm)	32
Construction	6061-T6 Aluminum
Type of Illumination	Accessory
RoHS	Compliant

---



## Appendix D:

The following table contains the specifications of the multimode fiber we are planning to use in the beamsplitter method (see. **Fig.3**)

### 0.10 NA Multimode Step Index Optical Fiber, Stock No. #HPSC25

Wavelength	=	400 - 500 nm and 700 - 1400 nm
Numerical Aperture	=	0.100 ± 0.015
Core index	=	Proprietary <sup>1</sup>
Cladding index	=	Proprietary <sup>1</sup>
Core Diameter	=	25 ± 3.0 μm
Cladding Diameter	=	125 ± 2.0 μm
Coating Diameter	=	245 ± 10 μm
Core/Clad Concentricity	<	1.0 μm
Coating	=	Two-layer Acrylate
Operating Temperature	=	-60 to 85 °C
Wavelength	=	400 - 500 nm and 700 - 1400 nm
Numerical Aperture	=	0.100 ± 0.015
Core Diameter	=	25 ± 3.0 μm
Cladding Diameter	=	125 ± 2.0 μm
Coating Diameter	=	245 ± 10 μm
Operating Temperature	=	-60 to 85 °C

This proprietary information is not provide

## Reference

---

- [1] LightMachinery <https://lightmachinery.com/optical-design-center/more-optical-design-tools/gaussian-beam-propagation/>
- [2] Abraham, Lasers and Optical Fibers in Medicine, Laser Safety-Fundamentals
- [3] Edmund Optics
- [4] Thorlabs Lens Tubes, [https://www.thorlabs.de/newgrouppage9.cfm?objectgroup\\_id=3306](https://www.thorlabs.de/newgrouppage9.cfm?objectgroup_id=3306)