

Design Description Document

Eric Kwasniewski, Mark Ordway, and Aaron Greenbaum

Design Draft Revision **G**

Date: 5/5/2017

Table of Contents

I.	Functionality of Design	Page 1
II.	Theory	Page 1
	A. Dark Field with scratches	Page 2
	B. Scattering with scratches	Page 2
III.	Preliminary Data	Page 3
IV.	Optimax Characterization	Page 7
V.	Original Design	Page 8
VI.	Block Flow Chart	Page 8
VII.	Illumination Design	Page 9
VIII.	Auto Characterization	Page 15
IX.	Proof of Concept Demonstration	Page 17
X.	Design Schematic	Page 18
XI.	Past Ideas and Designs	Page 21
XII.	Budget	Page 22
XIII.	Future Plans + Misc.	Page 23
XIV.	References	Page 27

Functionality of Design:

This design describes a device that can find defects on a polished spherical surface and quantitate them automatically. The device must be able to output in the ISO 10110 standard, where the smallest defect size is 0.7 μm . The device cannot be destructive towards the optic, and thus cannot touch the surface in any way. We are responsible for designing the device itself, and the code to process the images and output.

Theory:

Dark Field Illumination for scratches

Scratches are lined with groves that behave similarly to a diffraction grating, causing scattering in random directions. This effect can be exacerbated by material piling up in the grooves such as dust or splinters of cracked glass. This makes the scattered light difficult to predict, thus there is no general rule for which observation angle will capture the most scattered light. It has been experimentally tested, which have concluded the best results were collected while the angular separation of the camera and the incident ray should range within 8 to 20 degrees.

Investigation of light scattering for scratch detection

A study was done in 2008 in the investigation of light scattering one surface defects. The study was entirely experimental. In it, the authors measured the intensity of scattered light when varying polarization, detection angle, condenser lens focal length, scratch angle, and scratch size. Below is a diagram of their setup.

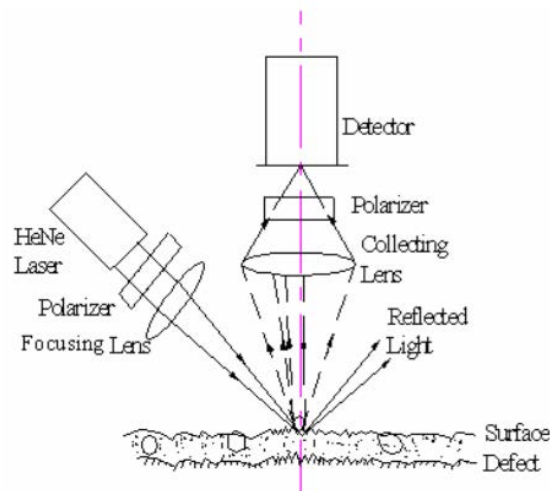

Fig. 1. Schematic diagram of experimental setup.

Because scratches often have a diffraction grating pattern inside them, this experimental setup used a Variable Frequency Resolution target, which is a test plate that contains frequencies from 5 LPM to 200 LPM with 5 LPM step increments.

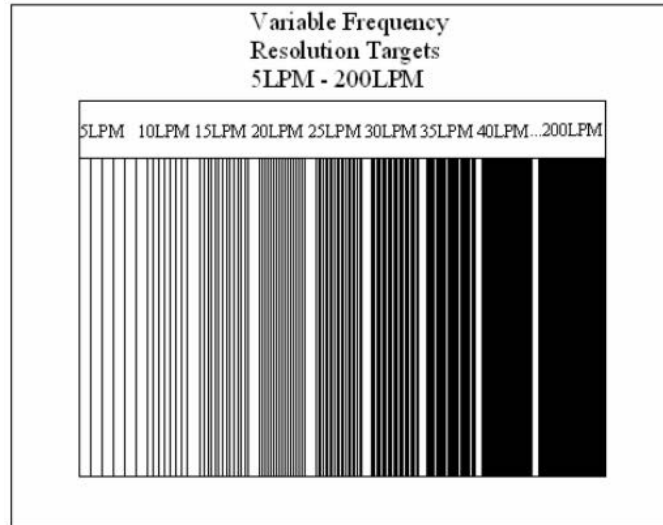

Fig. 2. Schematic diagram of the test plate sample.

There are some notable differences between this experiment and our design. Firstly this experiment uses a directional He-Ne laser with a 620 micron spot size. Secondly, this experiment uses a grating to simulate scratches of different sizes while our design considered singular scratches with gratings in them. Lastly, this experiment does not image the scratches but only measures the total power.

The result of their experiments determined that not using a focusing lens to focus the laser beam gives greater power from the scattered light. Another conclusion made is that the viewing angle of the detector should be 0 degrees from the angle normal for the highest intensity, this contradicts the article "Dark Field Illumination for scratches", which says that the detector must be 8-20 degrees from the angle of reflection. The angle of the grating had minimal effect on the intensity as this experiment's results showed that at low spatial frequencies the angle makes no difference and at high spatial frequencies the grating being perpendicular to the viewing angle gives a very slightly higher power (about 25%). They also displayed through their experiments that that using a polarizer reduced the power.

Preliminary Data:

Environment

At room temperature and humidity (22 °C and 50% humidity)
Industrial lighting overhead

Test piece

Uncoated optic, poor surface quality, 1 inch diameter, Convex spherical, unknown material, radius of curvature of 70 mm.

Microscope

Opti-tekscope, Model OT-HD

5-30 mm focal distance, 1-300x mag, 1 cm clear aperture.

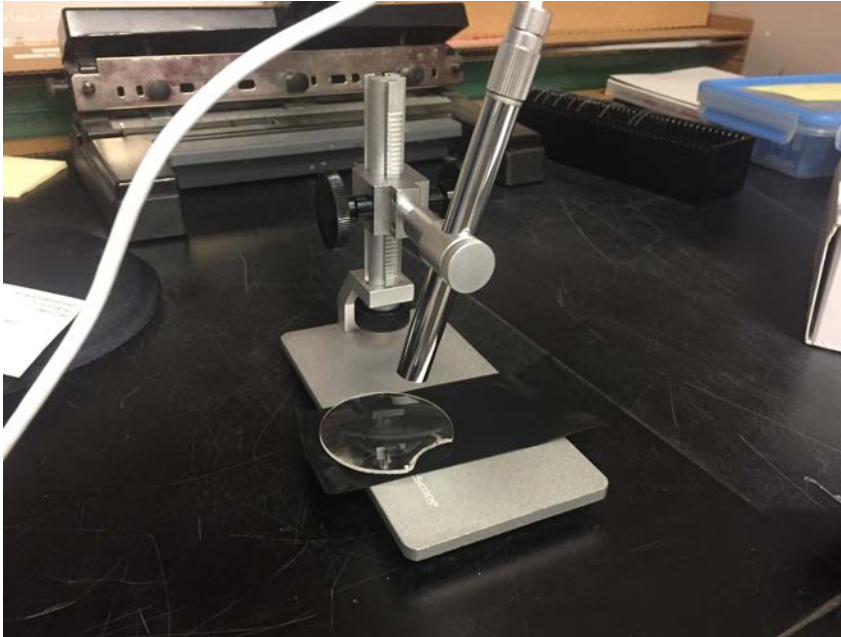

Figure 3: Opti-Tekscope imaging a lens surface. The industrial lighting is present and adding ambient light into the system. Black masking tape is used to absorb light from our improvised light source (Not in picture).

Light source

The first light source is a brightfield light source that has been integrated into the microscope. A ring of 8 LED lights surrounds the objective piece.

The second light source is a dark field light source meant to imitate the source shown in “design draft #1”. The light source is a cell phone light held at various angles similar to how it is depicted in “design draft #1”.

Data

Using this microscope, and test piece, the same spot on the lens was imaged under different lighting conditions at 20x magnification. First with no source, using only the ambient lighting to image. Then using the brightfield source that came with the microscope. Lastly, using a phone to imitate a white light dark field source with the phone being held at different angles.

In each image there is a 500um wide scratch and a 1-7 um wide scratch-like imperfection to the left of the 500um wide one. There are also many small surface imperfections (not dust) scattered across the lens surface.



Figure 4: x20 mag picture of lens under Darkfield at 0 degrees. Ambient lighting still present.

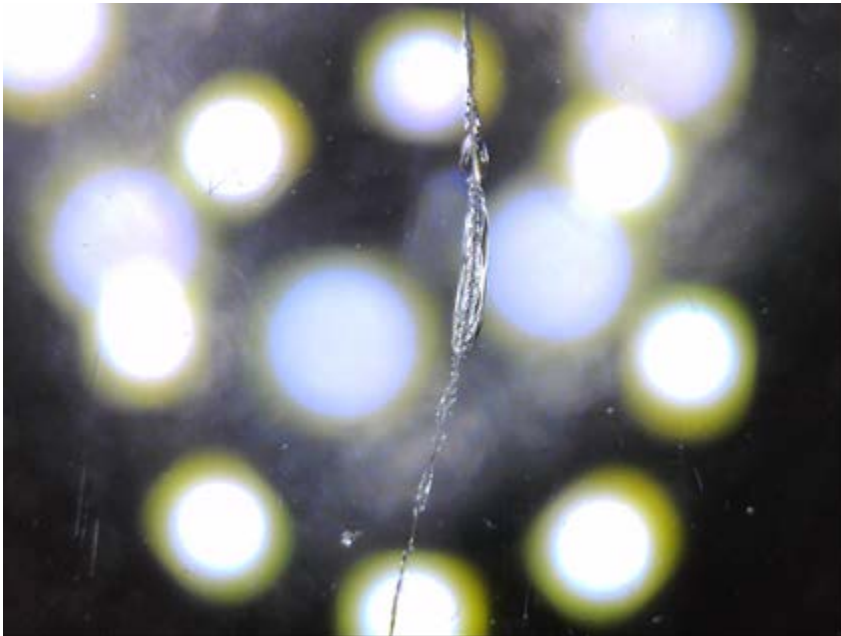

Figure 5: x20 mag picture of lens under integrated bright field.



Figure 6: Picture of lens with no additional lighting present. Only ambient light.



Figure 7: Picture of lens under darkfield lighting with source angled at 30 degrees above the ground. Less contrast of small features.



Figure 8: Picture of lens under darkfield lighting with source at 60 degrees from the ground. The light from the source can be seen at the bottom of the picture.

Figure 4 visibly shows the most surface imperfections out of all the other illumination methods. Figure 4 is a dark field source at 0 degrees from the ground. Using a darkfield source at a low angle may be the best approach to finding surface imperfections.

One interesting thing to note is the presence of ambient light in figure 5. This is the light from the industrial overhead lighting. Despite its noticeable presence in the image, the surface imperfections are still clearly visible. The background lighting may make it harder to write the program to detect/quantize the imperfections.

Method Optimax uses for characterization of Lens

Using a powerful light source, a test lens is illuminated through transmission from behind. Changing the angle of the test surface causes light to scatter off the surface imperfections allowing the inspector to locate the surface imperfection for further measurement. Once located, the SI is marked with slurry and viewed using a 20x microscope. The width and length of the SI is measured and the approximate area is calculated.

Original Design

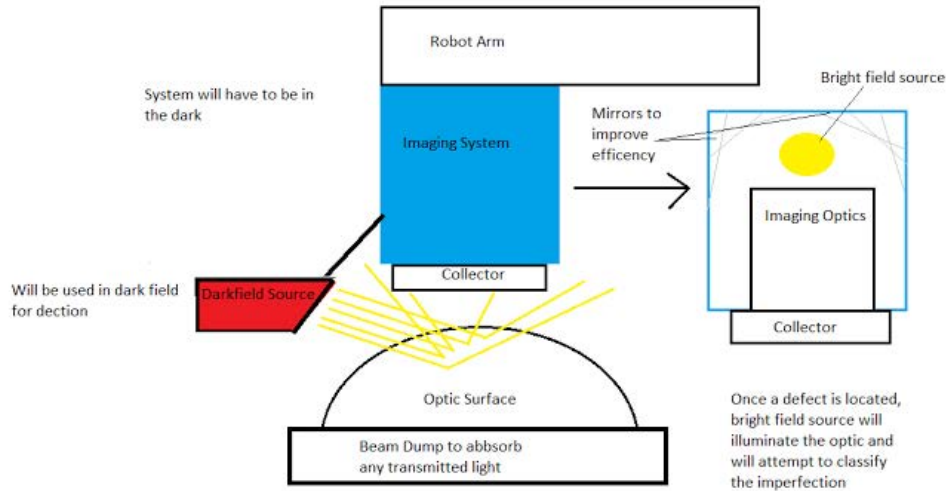

Figure 9: This was our preliminary design from last semester

Our original design for the device is to have the imaging system locate the defects with a large field of view dark field system. Once found, the defects will be characterized with a high resolution system. The translation will all be done with the robotic arm the system is attached to while the optic stays stationary.

Block flowchart

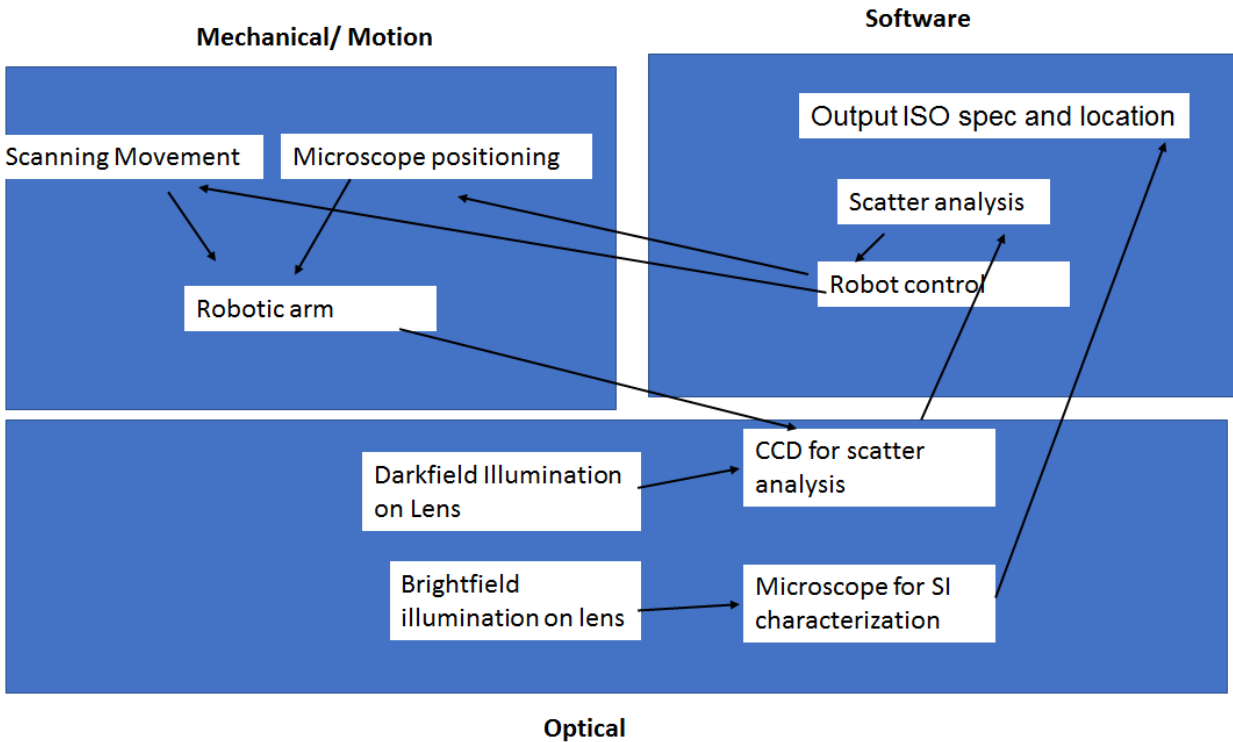

Figure 10: This plot highlights all of the challenges of this project and how they relate to each other. This was our guideline for our timeline goals shown on the next figure.

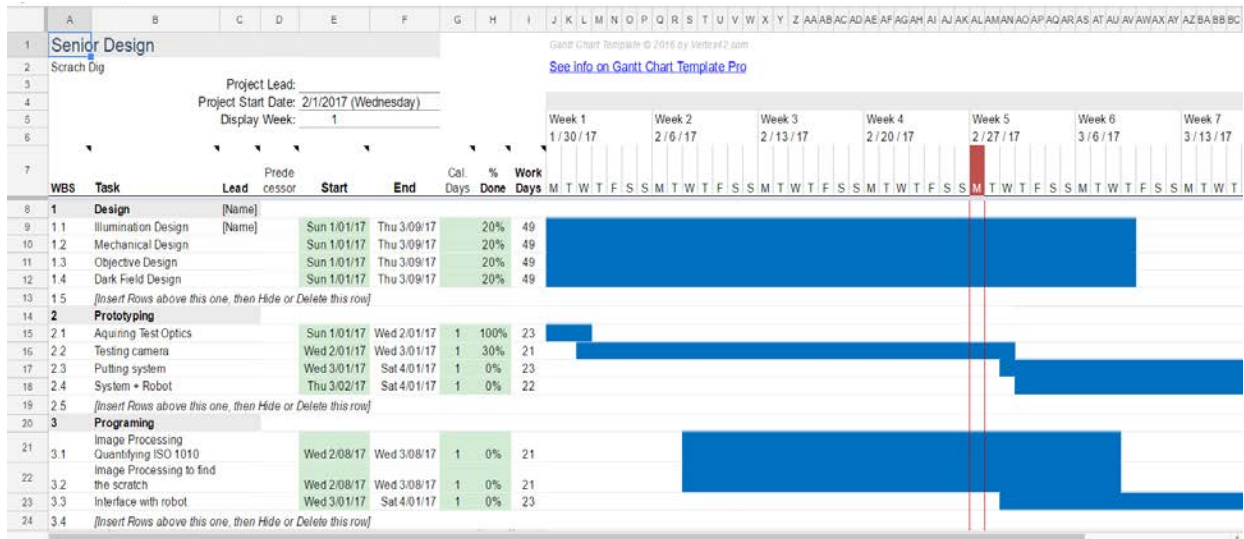

Figure 11: This is a Gantt chart of our timeline. We were unable to build a prototype due to the time it would take to build and the amount of time we would have had left.

Current Design: Illumination System

Below is a CodeV and lighttools simulation of how the sample surface can be illuminated using a small uniform planar light source, a condenser lens, and a prism. In order to illuminate the source at different angles, copies of this system will have to be placed around the barrel of the primary imaging optic, all illuminating the same spot.

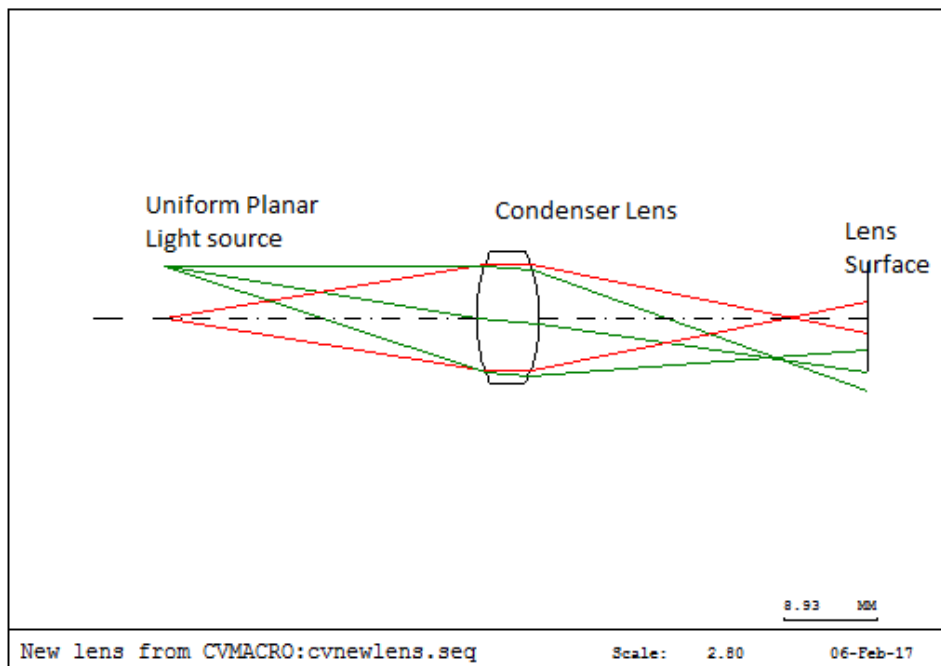

Figure 12: CodeV picture of single lens illumination system. Prism not included. The poor quality of a single lens system focuses the 10x10mm light source onto a 2x2mm area.

Using light tools, a simulation is made to see how well the system will illuminate the imaging area. For this example, a working distance of 30mm and a barrel diameter of 20mm is

assumed. Additionally, the housing of the system is not included for a better visual representation of the system.

The irradiance on the sample surface is also shown. The peak irradiance occurs around the center of the sample surface extending out in a circular shape with a diameter of 2.5mm. About half the peak irradiance continues to extend out from the center with a diameter of about 12mm. Beyond this the irradiance is extremely small.

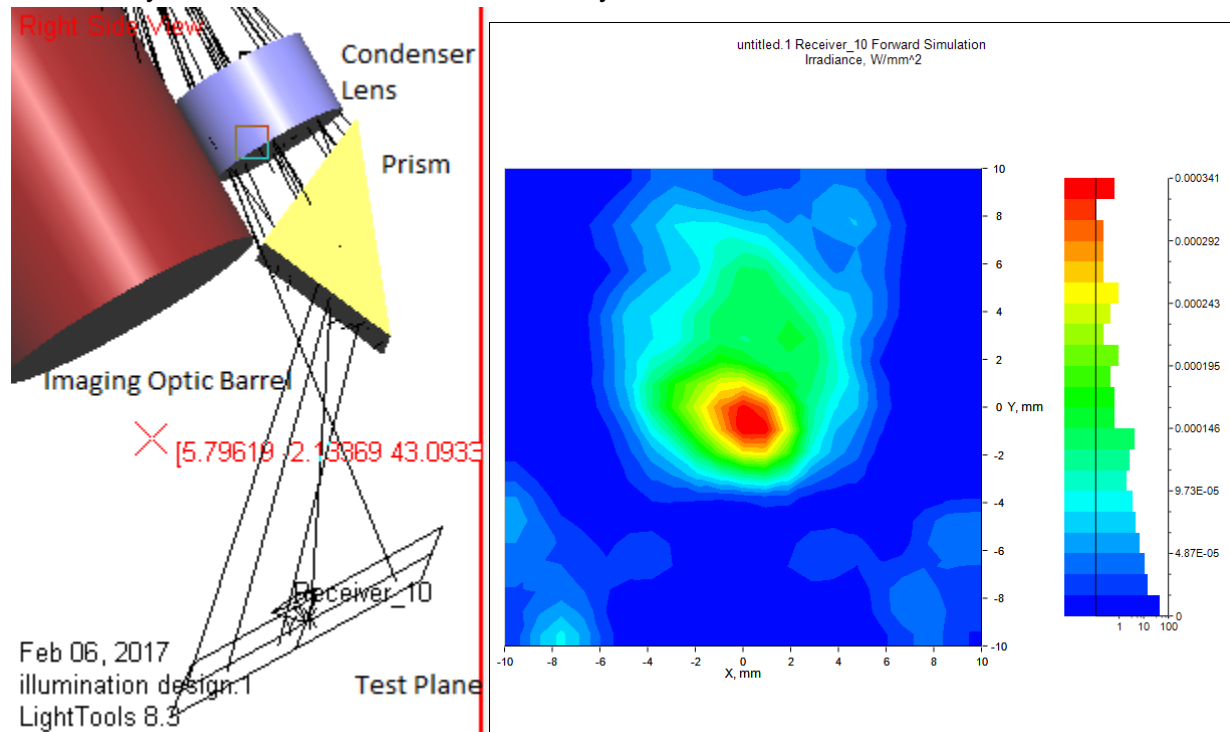

Figure 13: On the left is the lighttools 3D rendering of the System, the sensor cannot be seen but it is a 10x10mm planar light source. On the right is the irradiance map on the sample plane.

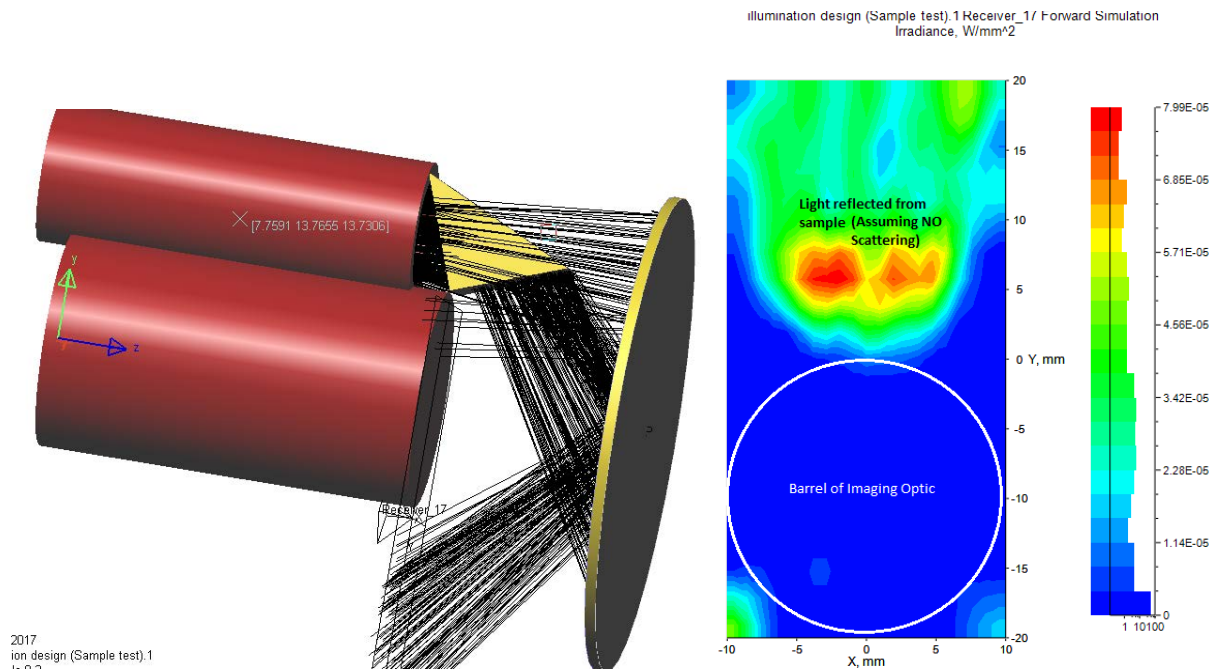

Figure 14: On the left is the lighttools 3D rendering of the System with Barrel. From the right side we can see that the light, assuming no scattering, does not reflect into the imaging optic.

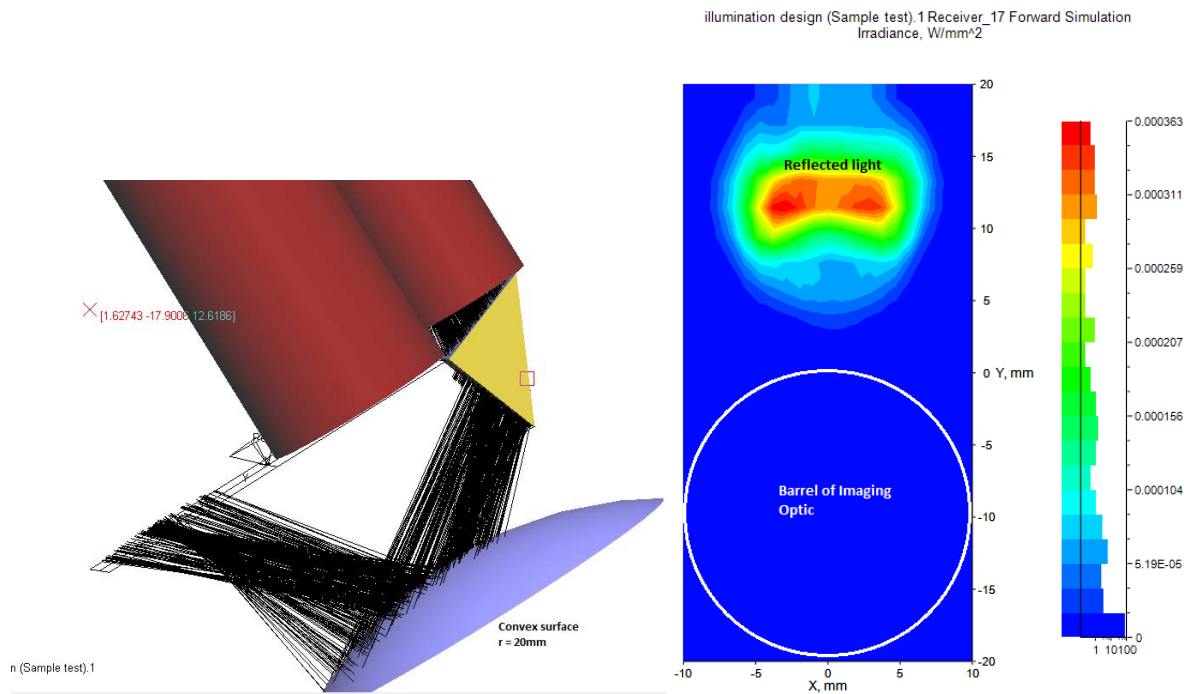

Figure 15: Same as figure 13, but with a convex surface of radius 20mm. Reflected light does not enter the barrel.

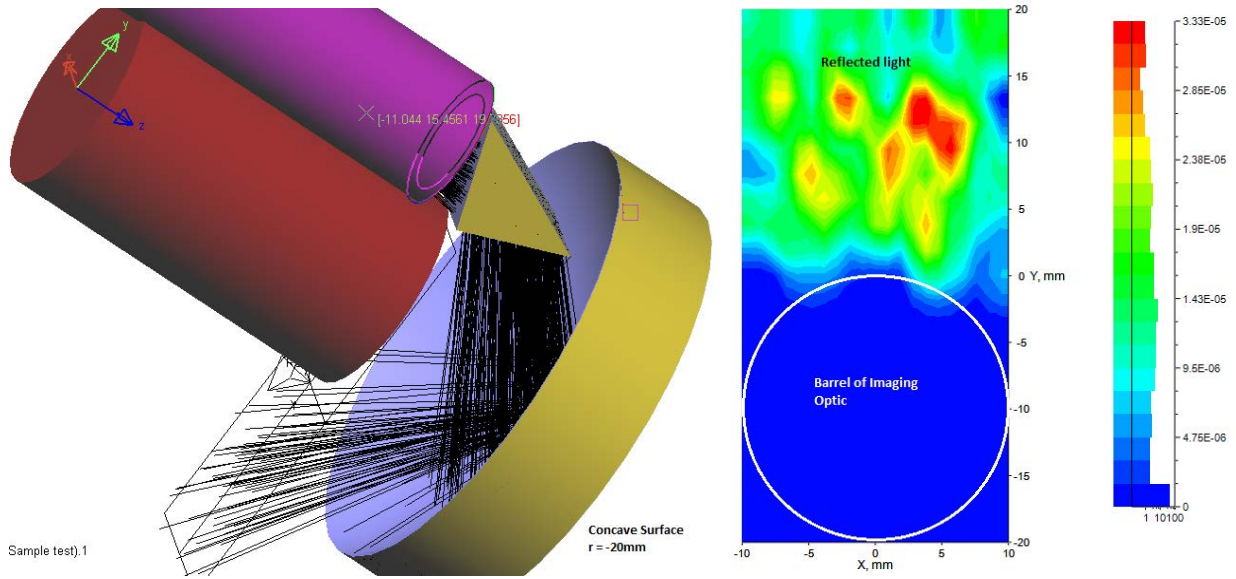

Figure 16: Same as figure 13, but with a concave surface of radius 20mm. Reflected light does not enter the barrel except by a close margin at the nearest edge.

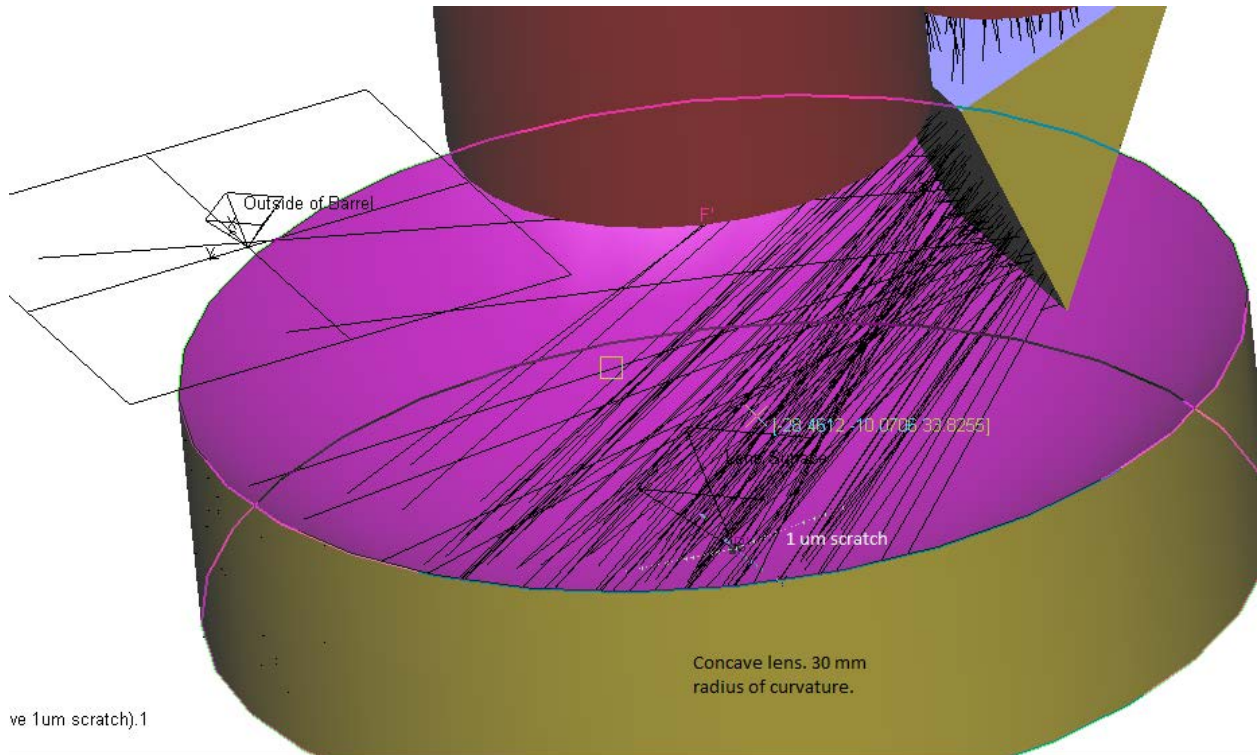

Figure 17: Added two 1 micrometer scratches to the surface.

illumination (concave 1um scratch).1 System Barrel Forward Simulation
Irradiance, W/mm^2

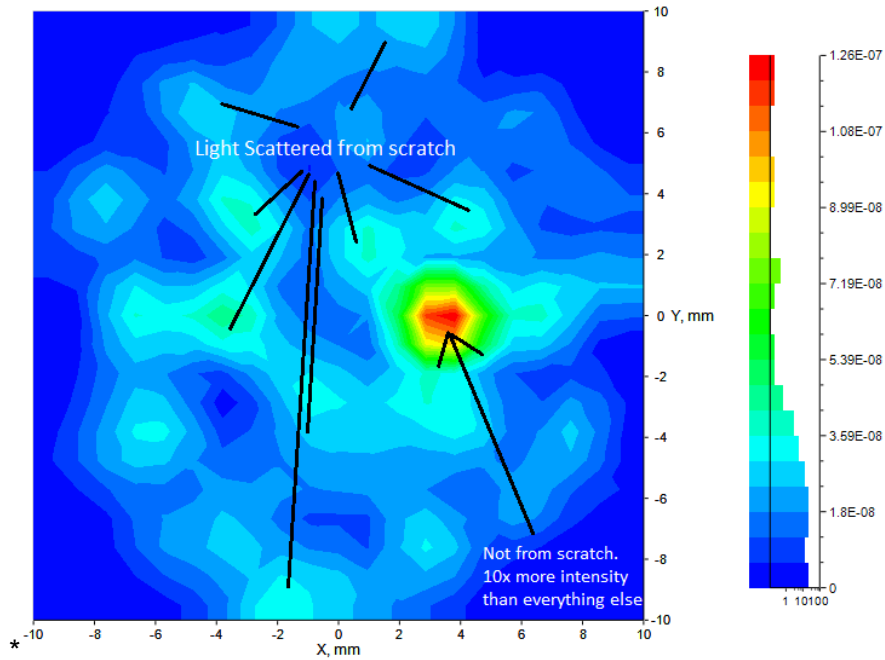
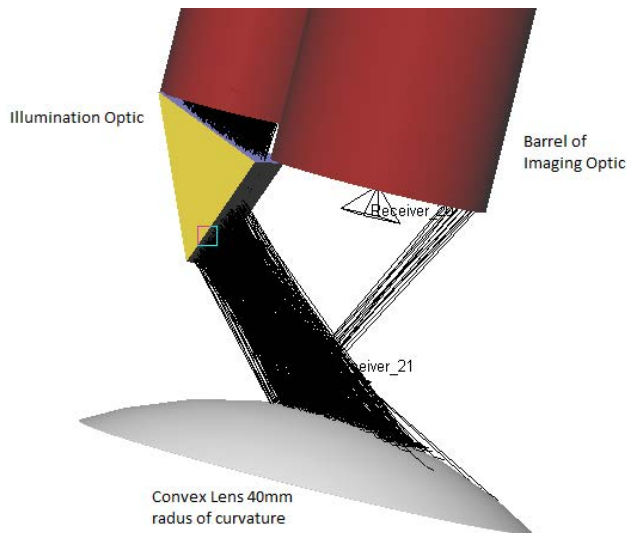

Figure 18: The illumination on the barrel of the imaging optic, the high intensity dot is not from the scratch as it remains in the intensity chart even after the scratch is removed.



Feb 22, 2017
illumination design extended-a.1
LightTools 8.3

Figure 19: Convex lens with radius of 40mm. No scratch is included because it was drowned out by reflection.

illumination design extended-a.1 Receiver_20 Forward Simulation
Irradiance, W/mm²

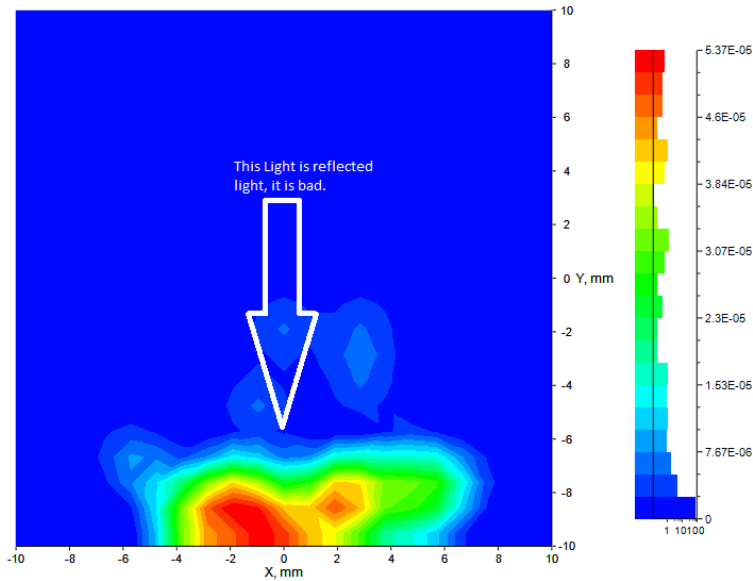

Figure 20: Some Light reflected from sample enters the barrel of imaging optic, it is 100 times more intense than light scattered from 1 μm scratch.

Latest light Tools Design

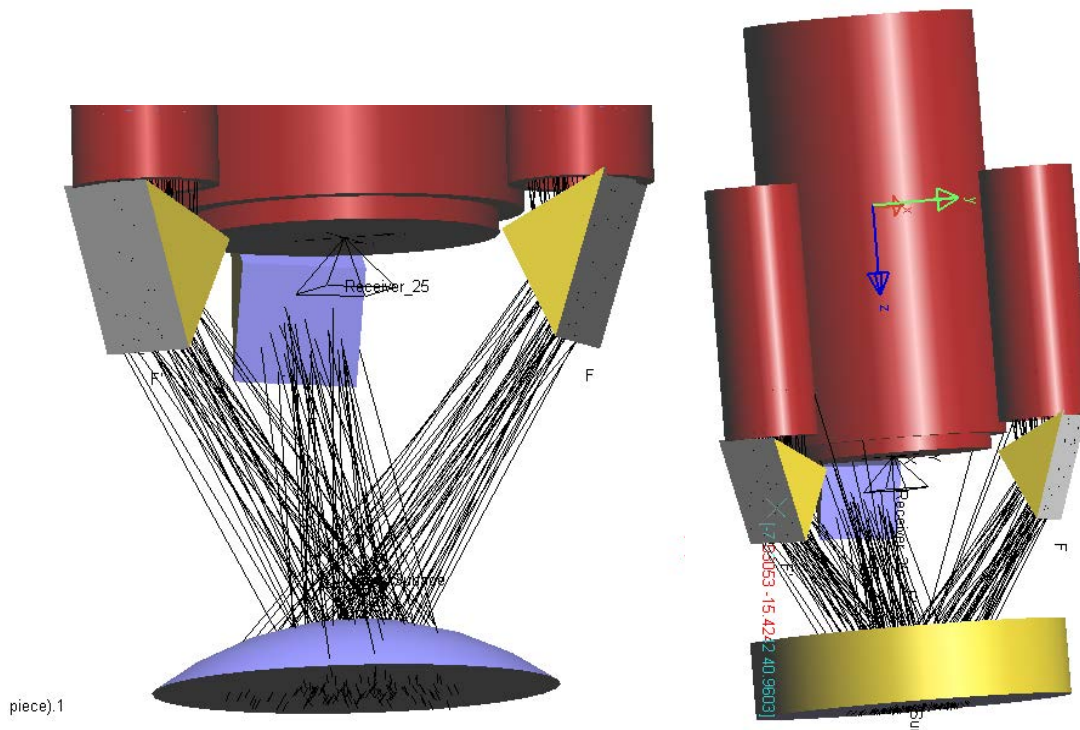

Figure 21: Lighttools design using the barrel dimensions of the microscope objective we picked out. Incorporated the 2 other identical illumination components to reflect the final design.

illumination (convex 1um three piece).1 Lens Surface Forward Simulation
Irradiance, W/mm²

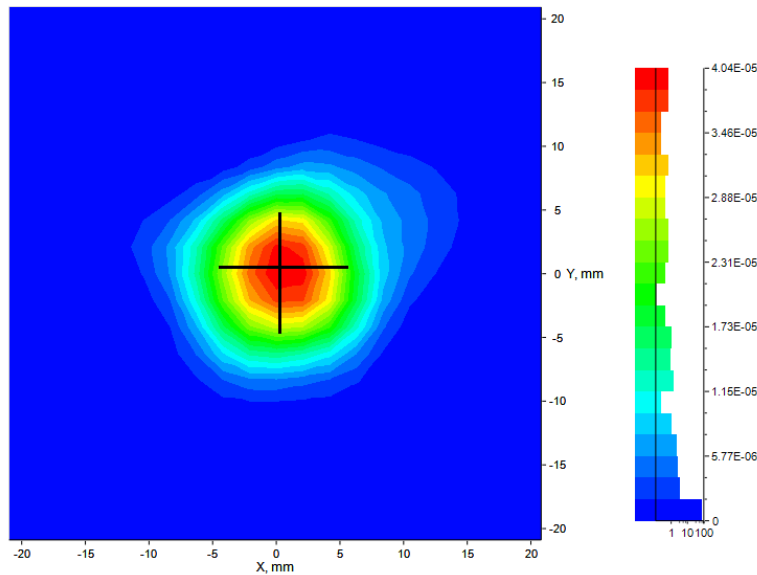

Figure 22: Illuminance on the surface of the lens. The two lines in the center represent the scratch put on the surface.

illumination (convex 1um three piece).1 Receiver_25 Forward Simulation
Irradiance, W/mm²

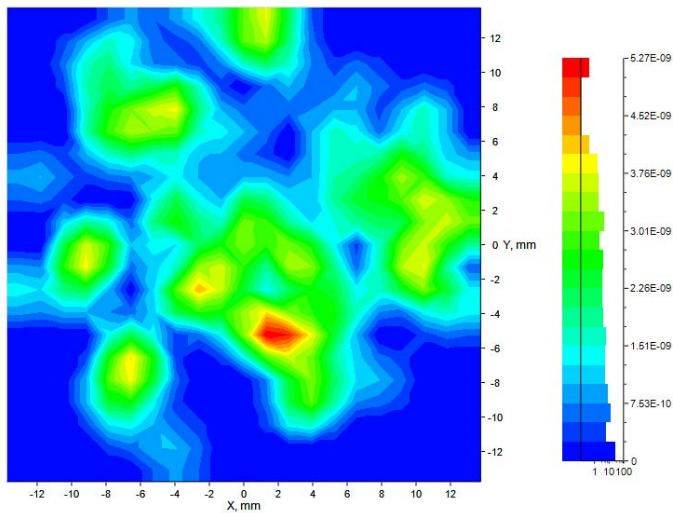

Figure 23: Illuminance across the barrel of the microscope.

Current design: Auto Characterization Program:

In order to enable our design to automatically characterize the Surface Imperfections, we will need to have an automated image processing program to analyze our data. Due to the widespread use of matlab in addition to its large library of useful image processing functions, the software is being written on matlab. The images that get fed into the program go through many steps that allows us to isolate SIs and measure their area, location, and width.

Matlab program

Step 1. Enhance and locate darkfield image scratches

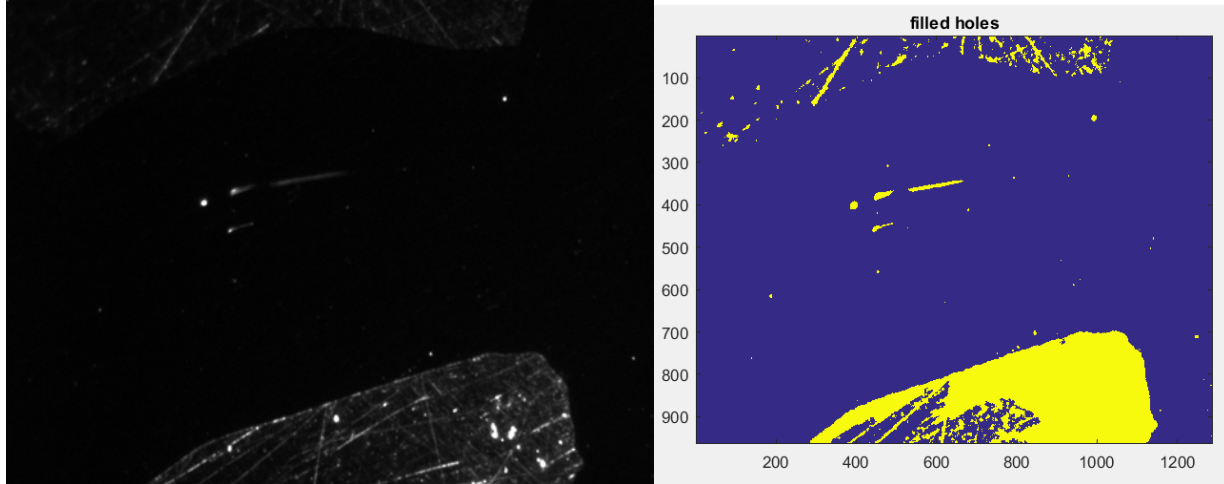

Figure 24: Original Image is enhanced to better see scratches. Locations and areas are known, future program will determine if a region is a scratch by calculating residual variance from best fit line. Regions with high R will be considered a scratch.

Step 2. Enhance and calculate width of scratch from 20x microscope image.

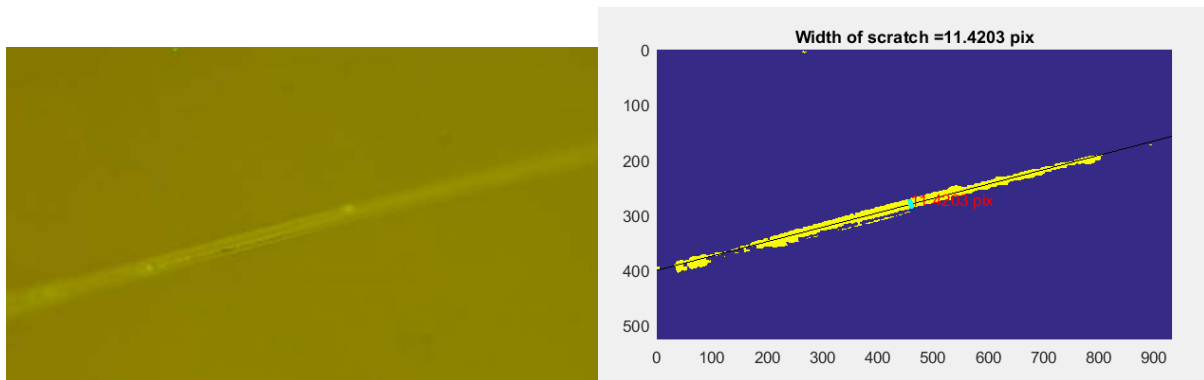

Figure 25: Input image is taken and used to calculate the width of the scratch automatically. Width is calculated from the average thickness of the scratch.

A simplified process for the program currently being developed is as follows.

For the brightfield image part, first the image is loaded into matlab where a bw threshold is applied. Grayscale values below the threshold become 0 and values above become 1. Then a

label function is applied such that each group of 1s surrounded by 0s is given a number (eg group 4). Then a function called regionprops is used to find the centroid and area of each group. The row in the data structure that is outputted relates to the group of the cluster of 1s. From there, the largest area group is found and fit with a best fit line that goes through the center of the SI. The slope of the best fit line is used to rotate the image such that the scratch is horizontal. From there the width of the scratch is added up and averaged to calculate the width of the scratch.

For the darkfield program, similar thresholding and labeling techniques are used. Each region is isolated and fit with a best fit line. Linear correlation coefficients are calculated and used to determine if a region is a scratch or not. The centroid locations are recorded to find the location on the image.

Proof-of Concept testing Demonstration

On March 24th our customer came to the University so we could show them that Darkfield illumination is the best approach to this problem. Below is a description about our setup and the results using this setup.

Setup

We created a setup using what was available to us at the University of Rochester to test the effectiveness of darkfield illumination for use in computerized scratch detection on lenses.

Our setup uses a 4x stereoscopic microscope, a Point Grey USB camera, a 1x microscope camera adaptor, 2 condenser lenses, and 2 fiber optic illuminators. A picture of the setup is shown below with a transmissive test lens provided by Optimax.

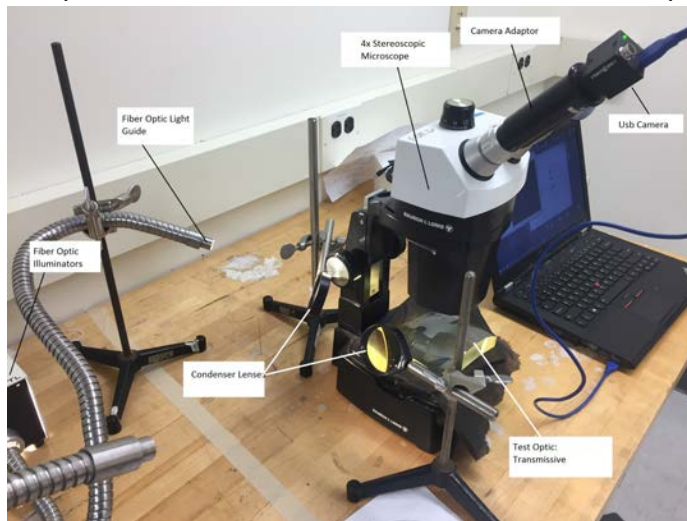

Figure 26: Setup of darkfield microscopy for inspection of surface imperfections on a lens.

Using this setup, images of scratches were taken from a variety of lenses and scratch sizes. We were able to easily detect scratches varying from 3 to 10 micrometers. Because the microscope could not mechanically position itself with respect to the stage, aside from the z-axis (vertical), the images taken did not always include scratches taken with the images system's optical axis perpendicular to the surface of the lens. The more the surface was, the better images we obtained.

Below are two example images of scratches taken using this system. The scratches are both easy to see and the dark background makes image processing possible.

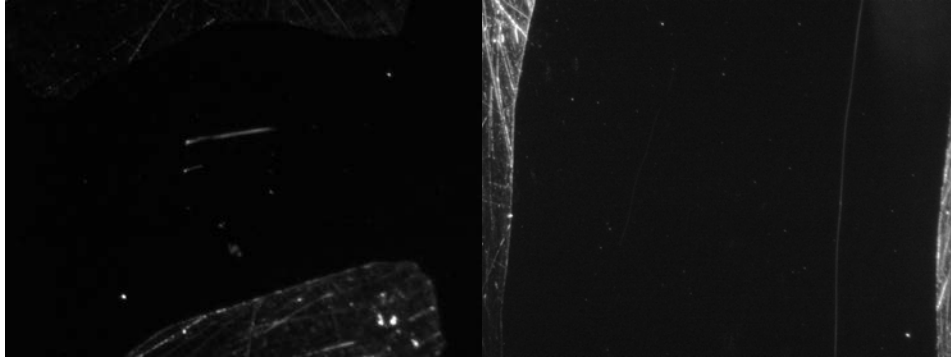

Figure 27: Left: Picture of transmissive lens. Right: Picture of reflective lens.

Our customer was impressed by the demonstration and requested a summary so they could apply for a budget to build a prototype of this machine.

Current design: Schematic

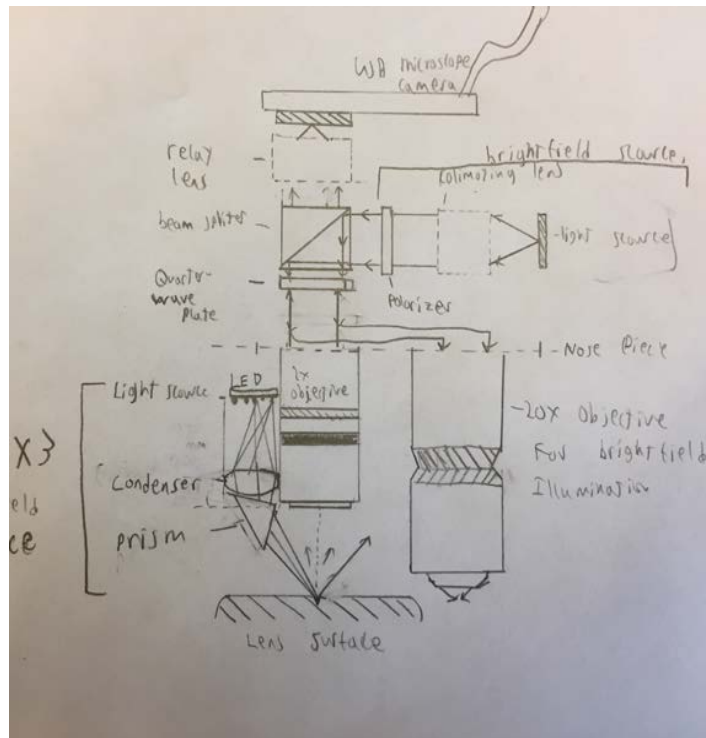

Figure 28: The handdrawn design for system.

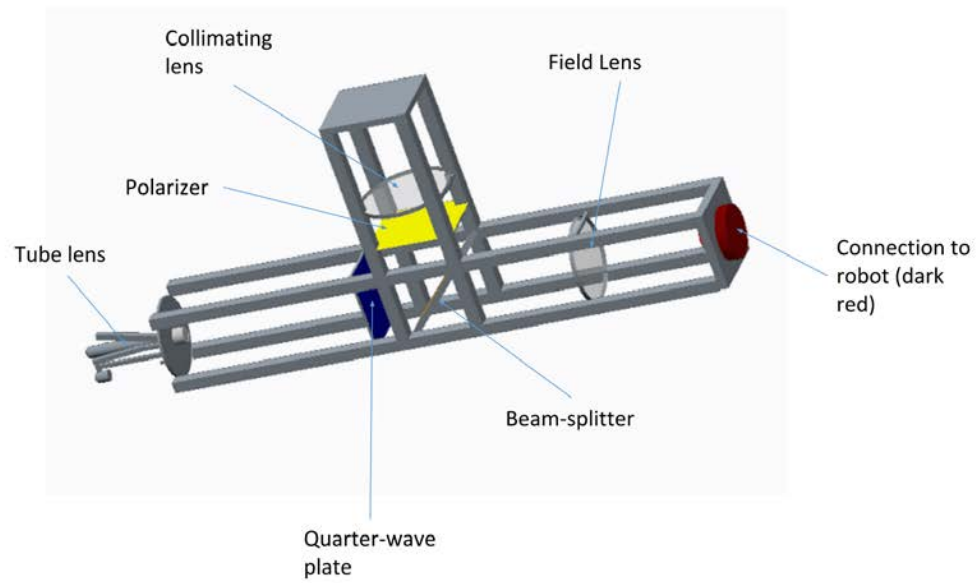

Figure 29: Mechanical Design for the system, not including housing compartment

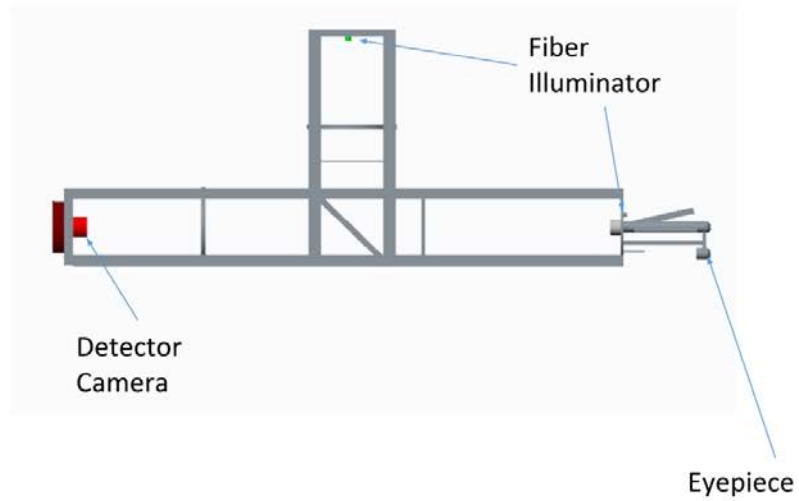

Figure 30: Horizontal view of the mechanical design

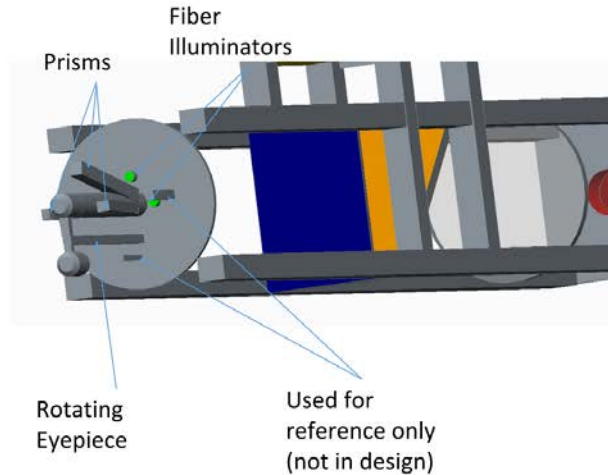

Figure 31: Mechanical design of the eyepiece

CAD model of our system, not including the casing. In bright field mode, the light will pass through collimating lens, polarized then reflected by beam splitter. The light will then pass through the QWP onto the surface of the lens. Light picked up from the objective will pass through the QWP again, causing it to pass through the beamsplitter due to $\pi/2$ phases shift induced from passing through the QWP twice. The light is then focused on the detector by the field lens.

In darkfield mode, the fiber illuminators will pump light through the prisms, to illuminate the sample in different directions. The low magnification 2x objective should be being used with the illumination system attached to it. The light will travel through the imaging system and pass through the beam splitter, where half of the light will be transmitted to the detector. If this were just a darkfield design, the beamsplitter can be removed to avoid splitting the power.

The brightfield source utilizes a beam splitter to allow for reflective brightfield illumination. It will only be turned on when the 20x objective is in use. The system will mechanically rotate it's two microscope objectives instead of having two entirely separate imaging systems. We have not designed the mechanical engineering on how to implement this rotation.

Past ideas and designs

We initially decided on using the RMM2 Roliscope for our darkfield design but due to issues in availability we decided to look at other options.

Super Luminous Imperfection Characterization Examiner (S.L.I.C.E.)

Using Brightfield Illumination we utilize a microscope to examine and characterize the located SIs. <http://spectraservices.com/product/unitron-rmm2.html>

Alternate: <http://spectraservices.com/product/motic-ba210-digital.html>

RMM2 Rollscop	
F/#	
FOV	22mm
Magnification	5x, 10x, 20x, 50x
Wavelength	Visable
Weight	15 lb
Dimensions	9" by 11" by 10"
Power requirements	6V 20W



Figure 32: Picture of the Roliscope microscope

Current design: Budget

Item	Price
Digital Dark Field Microscope	\$1964 Total
CM3-U3-13Y3M 1/2" Chameleon®3 Monochrome Camera	\$395
Mitutoyo to C-mount Camera 152.5mm Extension Tube	\$139
MT-4	\$695
2X EO M Plan Apo Long Working Distance Infinity Corrected	\$735
Digital Bright Field Microscope	\$663 Total
M-20X microscope objective	\$168
Field Lens	\$100
CM3-U3-13Y3M 1/2" Chameleon®3 Monochrome Camera	\$395

Dark Field Source	\$292-332 Total
2x prism - bk7 23 degrees	\$100-120 each
10x LEDWE-15 -white LED 13mW, about 1.5 lumens each (total 15 lumens)	\$92
L405P20 - 405 nm, 20 mW, Ø5.6 mm, B Pin Code, Laser Diode	optional
Brightfield Source	\$138.65 Total
Grid of leds LEDWE-9 (need to mounted)	\$82.2
Beam collimator-LB1092 f=15 biconvex bk7 ½ inch diameter	\$24.20
Polarizing beam splitter EBP1	\$32.25

Quarter Wave plate	???
--------------------	-----

Total Price	\$3,057.65
-------------	------------

Table 1: This is the table of the components and their price for our current design.

This budget does not include the cost of housing to connect/weld some of the parts together. Most of the parts do not attach together right after taking them out of the box. Only the CM3 camera, the Mitutoyo C-mount extension tube, the MT-4, and the 2X microscope objective are able to be attached together. Figure 29 shows pictorially how parts are held together but is not a comprehensive design. Figure 21 also pictorially shows how the illumination system will be housed but no detailed design as the prisms float in mid-air.

Future Plans

Our customer was very happy with our demonstration and parts budget. However, we did not order the parts in the above budget because, if we had, then the parts would have arrived on April 24th, giving us only 4 days to build the housing and put together our design. This would have been impossible because much of the housing hadn't even been designed. We did not to buy the parts.

Our customer still wants to see this further so he is thinking of continuing it as a mechanical engineering senior design project for next year. Because the optics is all finished, the mechanical engineering students will be responsible for building the housing and mechanical mechanism in the system. We will have to make sure our customer knows what to ask of the mechanical engineering students.

For the optical design, future improvements could include optimizing the relay lens/system and the field lens, cost effectively increasing the illumination NA for the darkfield illumination part, and increasing the field of view for the darkfield part.

Introduction and Design Requirements

Whenever any lens manufacturer makes a lens they need to test the lens to make sure it meets the customer's quality specification. One of the specifications is the cosmetic specification, which deals with surface imperfections such as scratches and digs. The process for testing this specification involves an inspector observing the optic under light with his/her bare eye. This process is very time consuming and strenuous for the inspector.

Optimax is one such company and they want us to design a machine to do this process automatically. It must find defects on a polished spherical surface and quantitate them automatically. The device must be able to output in the ISO 10110 standard, where the smallest defect size is 0.7 μm .

Theory

Scattering

Scratches are lined with grooves that behave similarly to a diffraction grating, causing scattering in random directions. This effect can be exacerbated by material piling up in the grooves such as dust or splinters of cracked glass. This makes it difficult to predict, and from many research papers it has been concluded that there is no general rule for how light scatters off a scratch. We have found out from papers that did empirical testing, that best results were collected while the angular separation of the camera and the incident ray should range within 8 to 20 degrees.

Dark Field Microscopy

In order to identify the objects our system will use darkfield Microscopy in reflection. The high contrast will allow the System to see the presence of scratches.

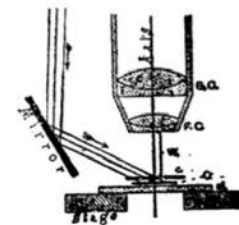
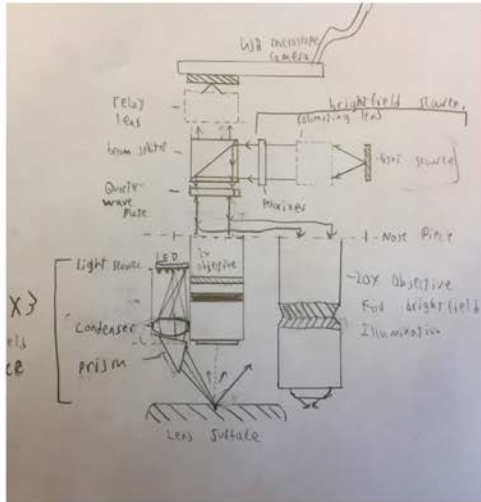

Fig. 3. Light from above the stage. (From *The Microscope*)

Design + Schematic



Using 5 13mW LEDs per source, the darkfield illumination system has 3 systems around it to illuminate a larger angular spectrum.

This is the design taking into account the objective we picked out.

The brightfield source, shown on the left, utilizes a beam splitter to allow for reflective brightfield illumination. It will only be turned on when the 20x objective is in use. The system will mechanically rotate its two microscope objectives instead of having two entirely separate imaging systems.

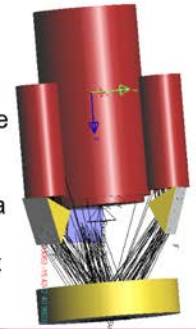

Software development

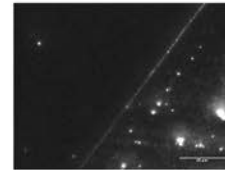
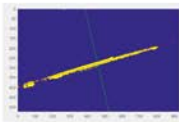
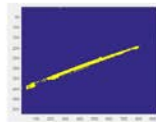

Original image is taken through multiple image processing techniques in order to separate SI from dust, find width, location, area.

Will use data like this to locate the SI under Darkfield illumination

Basic process: Load > threshold > Label clusters > Regionprops > Area data to eliminate dust and glare > linear fit to cluster > normal line > Rotate image along line > edge finding image subtraction > calculate width ... Use centroid to accurately tell location.

Program written in Matlab

Budget

Item	Price
Digital Dark Field Microscope	\$1964 Total
CM3-U3-13Y3M 1/2" Chameleon®3 Monochrome Camera	\$395
Mitutoyo to C-mount Camera 152.5mm Extension Tube	\$139
MT-4	\$695
2X EO M Plan Apo Long Working Distance Infinity Corrected	\$735
Digital Bright Field Microscope	\$663 Total
M-20X microscope objective	\$168
Field Lens	\$100
CM3-U3-13Y3M 1/2" Chameleon®3 Monochrome Camera	\$395

Dark Field Source	\$292-332 Total
2x prism - bk7 23 degrees	\$100-120 each
10x LEDWE-15 -white LED 13mW, about 1.5 lumens each (total 15 lumens)	\$92
L405P20 - 405 nm, 20 mW, Ø5.6 mm, B Pin Code, Laser Diode	optional
Brightfield Source	\$138.65 Total
Grid of leds LEDWE-9 (need to mounted)	\$82.2
Beam collimator-LB1092 f=15 biconvex bk7 ½ inch diameter	\$24.20
Polarizing beam splitter EBP1	\$32.25
Quarter Wave plate	
Total Price	\$3,057.65

Schedule

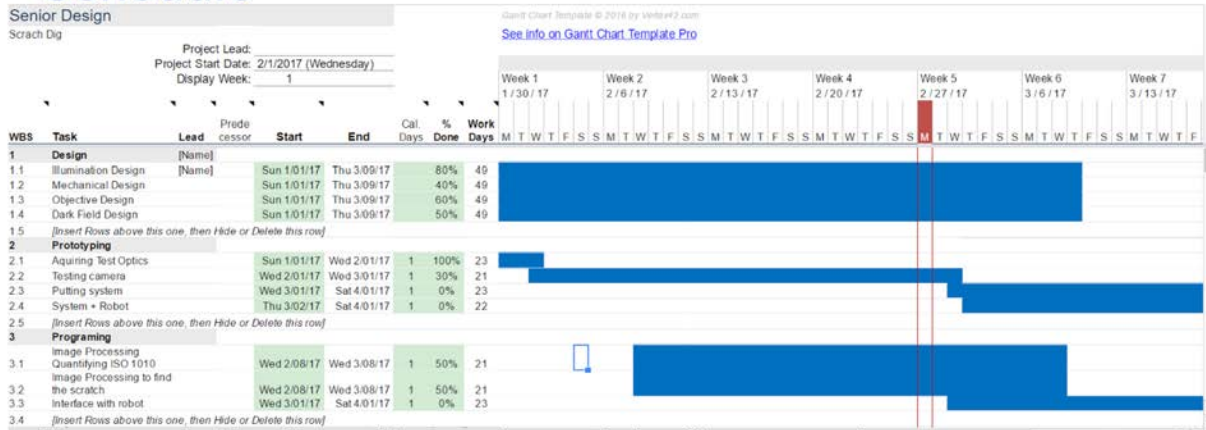

We are on schedule with everything except camera testing. Since we cannot accurately predict how light scatters its hard to calculate what camera to use.

Next Step: Customer comes in to look at setup, then prototyping

References

- 1) Z.W. Zhong, L.P. Zhao, L.J. Wang. Investigation of Light Scattering for Scratch Detection, Proceedings of SPIE, Vol. 7115, October 2008.
- 2) Bakolias, C., and A. K. Forrest. "Dark Field, Scheimpflug Imaging for Surface Inspection." *SPIE* 3029 (1997): 57-68. Web.
- 3) Cage, Simon. "Modern Dark-Field Microscopy and the History of Its Development : Gage, Simon Henry : Free Download & Streaming." *Internet Archive*. Transactions of American Microscopical Society, Apr. 1920. Web. 22 Feb. 2017.