High-Power Fiber Lasers: Recent Advances

I. Introduction

The field of Lasers has a relatively short history starting from 1960 with Maiman's first demonstration of laser action in ruby^[1]. The first fiber laser was demonstrated by Snitzer in 1961^[2]. Subsequently, Nd-doped fiber lasers were developed following the progress in bulk glasses. The first Nd-doped fiber laser was pumped from the side and could only work in the spatial multimode regime^[3]. However, side pumping provides very low efficiency, which was improved by the longitudinal pumping used by Burrus and Stone^[4].

The erbium-doped fiber amplifier(EDFA) was invented by D. N. Payne and coworkers in 1987^[5]. The commercialization of the EDFA made long haul optical communication inexpensive and reliable and optical fiber became the standard for long-haul telecommunication systems. However, in situations where high-power lasers are needed, an EDFA does not work very well because the high power density damages the fiber. Nd-doped fiber lasers (NDFL) and Yb-doped fiber lasers (YDFL) were developed for scaling output power of fiber lasers.

The first Yb-doped fiber laser was reported by Etzel, Grandy and Ginther^[6]. YDFLs attracted less attention initially since NDFLs were considered to have more advantages. Nd³⁺ has the advantage of a four-level pumping scheme, while Yb³⁺ works with a three or quasi four-level scheme. A four level laser system tends to lase easier because it has a lower threshold. However, ytterbium offers higher power conversion efficiencies and larger output powers. Pulsed lasers can get higher peak powers than CW lasers. In some applications, high power pulses are needed for diagnostics, laser surgery, and high quality imaging. High power pulses from fiber lasers can achieve good beam qualities. This makes such lasers attractive for practical applications.

This paper reviews CW and pulsed fiber lasers with a focus on YDFL for its high conversion efficiency. In the following discussions of high-power fiber lasers, output power and beam quality^[7] constitute two important parameters.

II. Enabling Technology for High Power Fiber Lasers

Fiber lasers have many advantages over bulk glass lasers. Fiber lasers are more compact, lighter, and more efficient than bulk glass lasers. In double-clad fiber lasers, pump conversion efficiency can be as high as 80%. Fiber lasers can have better beam quality than bulk glass lasers due to mode control and thermal managements. For example, flashlamp-pumped Nd: YAG lasers have limited beam quality because of the thermal lensing of the Nd: YAG rod. The thermal lensing is generated by the temperature gradient in the cross

section of the glass rod. For fiber lasers, fiber geometry increases the surface-to-volume ratio. This makes it easier to dissipate the heat. In addition, fiber lasers are normally easier to maintain compared with bulk glass lasers. They can operate over a long time span with high reliability. For these reasons, fiber lasers are considered to be the alternative laser sources for solid state lasers.

There are a few obstacles to be overcome when building a high-power fiber laser. First, high pump powers are needed to get enough energy into the laser systems. Pump lasers should provide more output powers than that of the fiber lasers. High power laser diodes have been developed in recent years and are available at power levels as high as hundreds of kW with combined laser diode arrays.

High optical powers can lead to optical damages of fibers. The silica damage threshold is about $5 \text{ W}/\mu\text{m}^2$. When the optical power inside the fiber is greater than this value, the fiber tends to be destroyed. Thermal effects can be significant in high power lasers too. Fortunately, the fiber geometry provides the advantage of good thermal management, and no extra units are needed for heat dissipations.

Nonlinear effects play an important role in high power fiber lasers. They are induced by the large amount of power density in the small area fiber core. Among the nonlinear effects, Brillouin backscattering can be the limitation of the output power for narrow-band signals; and Raman scattering can generate a frequency shift which decreases the pump power and signal power.

A. Rare-earth Ions and Laser Efficiency

Both neodymium and ytterbium are suitable doping elements for high-power fiber lasers. Neodymium can be pumped at 808nm to get good absorption, while ytterbium can be pumped at 975 nm for good absorption. Both of these elements can emit light around 1060 nm with slightly different energy transition mechanisms. Neodymium works as a four-level system near 1060 nm. It has a relatively low laser threshold. Ytterbium works as a quasi-four level system at 1060nm. Its energy level structure and the reabsorption effect make the threshold pump power relatively high. However, ytterbium does not have self-quenching effects as neodymium does and can have a higher ion concentration. Moreover, ytterbium can be more efficient due to the small quantum defects. All these advantages make ytterbium more attractive than neodymium as a doping element in fiber laser systems.

There are many energy transfer processes in rare earth doped fiber systems. The non-radiative transition depopulates excited states but does not generate any photons. In the cross-relaxation process, energy is transferred from the excited state of one ion to a neighboring ion. In the Nd^{3+} system, cross-relaxation is the main quenching mechanism. In the up-conversion process, one ion gives out energy and goes into the ground state, and the other ion absorbs the energy and gets excited to a higher level. From this level it may relax quickly downwards through a multi-phonon process. Additionally, the process of concentration quenching is understood as the quantum efficiency of an ion doped system decreases as the concentration of ions is increased. The other processes contribute to the concentration quenching.

To get a better prediction of fiber laser performance, the spectroscopic properties of the active medium need to be understood. In most cases, rare-earth doped glass fibers are used for the active medium. Yb^{3+} has

relatively narrow absorption bandwidth at 975nm and broad emission bandwidths that do not change significantly from one host to another. The ions have relatively long meta-stable lifetime, and yield relatively high quantum efficiency for fiber lasers. Fig. 1 and Fig. 2 show energy levels and spectra of the Yb^{3+} ions. Fig. 3 shows the energy level diagram of Nd^{3+} ions.

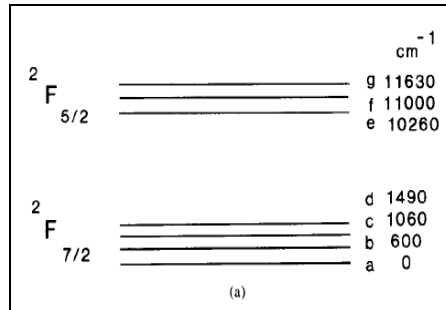

Fig. 1 Energy levels of Yb^{3+} . [8]

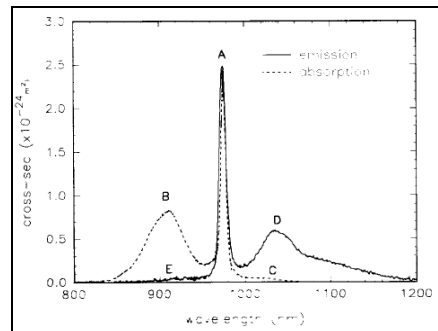

Fig. 2 Absorption and emission cross sections for a ytterbium doped germanosilicate host. [8]

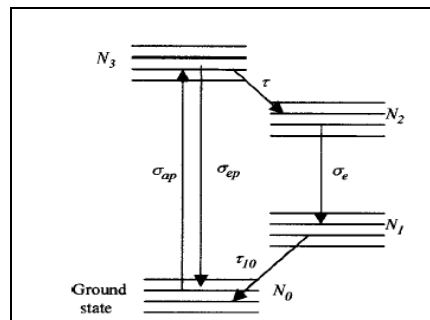

Fig. 3 Energy level diagrams of Nd^{3+} . [9]

The energy level diagrams explain why higher quantum efficiency and larger output power can be obtained with Yb^{3+} . The energy level diagrams of Yb^{3+} consist of two manifolds: the ground energy manifold $^2F_{7/2}$ and the excited energy manifold $^2F_{5/2}$. The Stark effect makes the excited manifold split into three sublevels and the ground manifold split into four sublevels. From the energy level diagram, it can be seen that there is no excited-state absorption at the pump or laser wavelength. In addition, because of the large energy gap between the ground manifold and the excited manifold, there is small possibility of multi-phonon emission from the excited manifolds. Thus little concentration quenching occurs for ytterbium in silica.

The wide absorption spectrum of Yb^{3+} makes it easy to configure the pump sources. In the silica host, the pump wavelength can extend from 800nm to 1060nm (In practice the pump wavelength can be chosen for specific applications). Similarly, the laser wavelength can extend from 970nm to 1200nm by using wavelength control technique such as the Bragg fiber gratings^[10]. The energy level diagrams can be matched with the absorption and emission lines. As shown in Fig. 2, peak A in the absorption and emission spectra is generated by the energy transfer between the lowest stark levels in each manifold. Peak B corresponds to the f to g absorption, and peak C corresponds to b-to-g transition. Peak C of the absorption spectrum can produce re-absorption in the Yb^{3+} doped medium, which increases the thresholds of fiber laser systems operating around 1000 nm.

For the emission spectrum, transitions from e to b, c and d lead to peak D. In these transitions, the energy sublevels c and d are almost empty so it can be treated as a four level system. Part E corresponds to the transition from the sublevel f, which generates very weak emissions in most situations.

B. High Pump Power and Double Cladding Fiber Structure

Historically bulk solid state lasers have been widely used for high power applications. They can be easily pumped with lamps. Fiber lasers require laser diodes for the pumping. Fortunately, the developments of high-power pump lasers and low-loss rare-earth doped fibers make high power fiber lasers possible^[11].

Since the first demonstration of a fiber laser^[2], there have been significant activities in this field^{[12][13][14][15]}. For high-power fiber lasers, low threshold is not of concern. Contrary to fiber communication systems where fibers are required to have small single-mode cores, small cores turn out to be an obstacle of obtaining high power laser outputs. In the single-mode laser diode pump configuration, the output power is normally restrained to below 1 W. Consequently, cladding pumping has been developed as an appropriate solution for this limitation^[50]. Cladding-pumped fiber lasers generate single-mode output signals with multimode pump lasers. With thick enough inner cladding, very high pump powers can be launched into a double-clad fiber. The only limitation on output is the available pump power. However, the core size limits the pump power to a certain amount because of optical damages and thermal effects. The pump conversion efficiency turns out to be an important factor influencing the output power. For the last ten years, double-clad pumping technology has been developing quickly, with the output power scaling from 1 W to over 100 W^{[16][17][18]}.

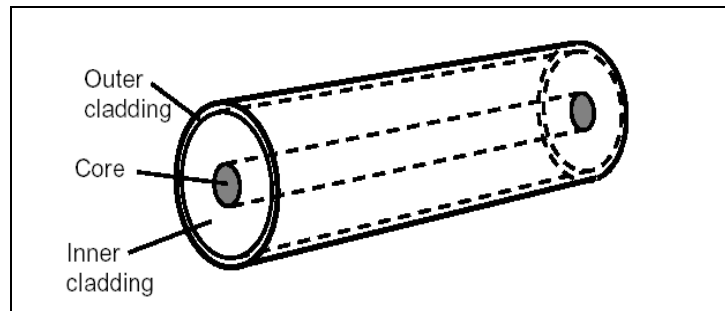

Fig. 4 Schematic drawing of a double-clad fiber.^[19]

The schematic drawing of a double-clad fiber is shown in Fig. 4. The outer cladding makes the double-clad fibers distinct from regular fibers. A typical double clad fiber is designed such that the core can only work with a single-mode output, with the inner cladding working in a highly multimode regime for the pump power. To increase the pump power in the fiber, the inner cladding is designed with a high numerical aperture. The inner cladding shape is normally non-circular to make more pump power to enter the fiber core; if the inner cladding is designed to be circular, then only few pump modes will cross the doped core. In this case, the pump efficiency will be low. However, the core can be offset from the center to improve the efficiency. For example, the absorption efficiency can be improved by 28% with the offset Nd-doped core.

The pump absorption efficiency changes with the inner cladding shape. According to Liu and Ueda^[20], the offset and rectangular inner cladding double-clad fibers can achieve four times higher efficiency than the circular inner cladding fibers. Fig. 5 shows several geometries for the inner cladding of double-clad fibers. In Fig. 6 and Fig. 7, the pump absorption efficiencies were measured to be four times greater in the offset and rectangular designed cladding fibers than circular ones.

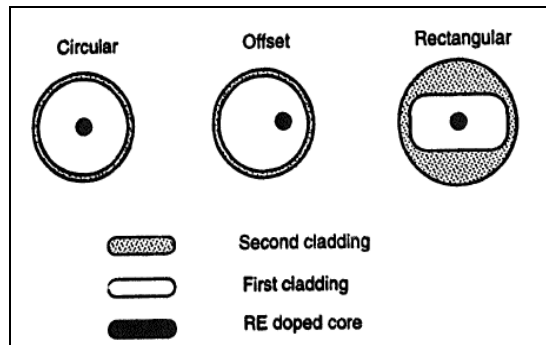

Fig. 5 Inner cladding shapes of double-clad fiber.^[20]

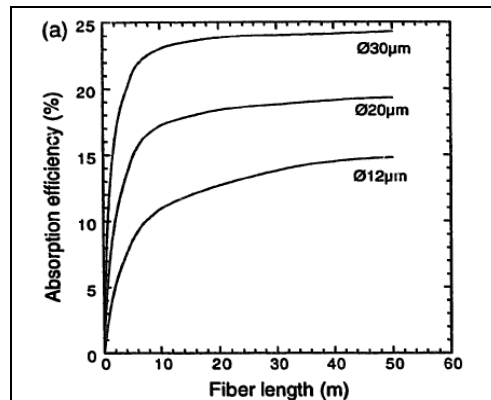

Fig. 6 Pump absorption efficiency of circular inner cladding fiber, Φ is the core diameter, inner cladding diameter is $400\ \mu\text{m}$.^[20]

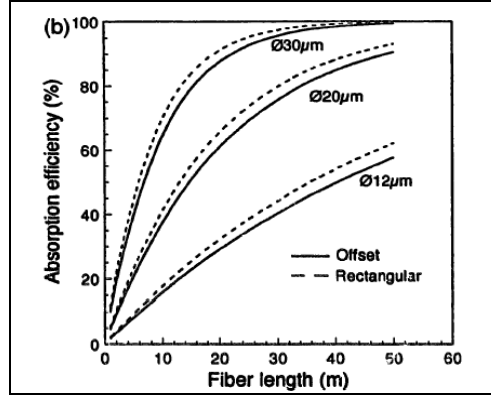

Fig. 7 Pump absorption of offset, rectangular inner cladding fiber, Φ is the core diameter, inner cladding diameter is $400 \mu\text{m}$.^[20]

C. Thermal Effects and Optical Damage

Thermal management is important for high-power fiber lasers. Fortunately, ytterbium-doped fiber lasers have extremely good thermal properties for the active medium physical properties. High conversion efficiencies lead to less than 15% pump energy converted into heat^[19]. Secondly, the fiber geometry makes the heat distributed over a long length. Even if there are some thermal effects for the coating, it can be solved by adding a heat sink.

Fiber facet damage is another problem when building high-power fiber lasers. In the multimode regime, it is relatively easy to get a high output power, but single-mode beam quality is much more challenging due to the optical damage. In a 2000 experiment^[21], high power density of $6.5 \text{ W}/\mu\text{m}^2$ was achieved. The Q-switched YDFL had 10 kW peak power carrying 2.3 mJ energy in one single pulse. In a 2000 experiment, a holey fiber Raman laser reached a CW power density of $2 \text{ W}/\mu\text{m}^2$ without fiber facet damage. Assuming that the CW damage threshold of a silica fiber is $5 \text{ W}/\mu\text{m}^2$, the fiber is required to have a core area of $200 \mu\text{m}^2$ for 1 kW output power. This core size produces multi-modes in the fiber cavity. Fortunately, mode selection techniques have been demonstrated to enable the single mode output in a multimode core fiber^[22].

D. Mode Selection and Nonlinear Effects

Large core size fibers are used to get higher output powers. To keep high beam qualities, fundamental mode outputs are required in most high power laser systems. Coiled fibers and mode selection tapers have been developed to solve this problem.

Coiled fibers are widely used to select the fundamental mode^[26]. In 2000, Koplów demonstrated a single mode output amplifier with a multimode coiled double clad fiber^[42]. The core diameter was $25 \mu\text{m}$ and the V number was 7.4. If the fiber had not been coiled, then multiple modes would have been generated from the output. By coiling the fiber, significant loss was induced to all other modes except the fundamental one LP_{01} , thus a single mode output was achieved with the multimode fiber. This technique can be used in

fiber lasers the same as it was used in the amplifier. In a 2001 experiment, fundamental-mode operation in a $2000 \mu\text{m}^2$ fiber core area was achieved with the coiling technique [23].

Mode-selective fiber tapers can be used for mode selection. By using fiber taper components [22], the multimode fiber core can be made to operate in the fundamental mode. In addition, large-mode-area fibers (LMA) can be used for mode selections. In 1998, Offerhaus [36] demonstrated that the LMA fiber gave out robust single-mode output. The refractive index profile of the designed large-mode-area fiber is shown in Fig. 8. The experiment setup is shown in Fig. 9.

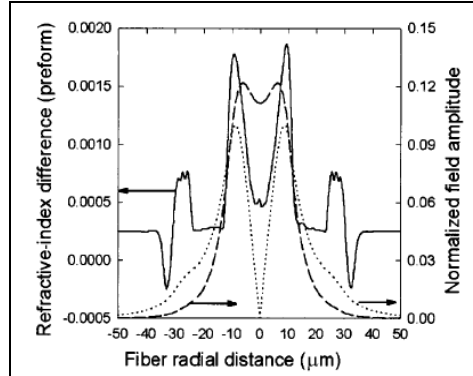

Fig. 8 Refractive index profile of a large-mode-area fiber. [36]

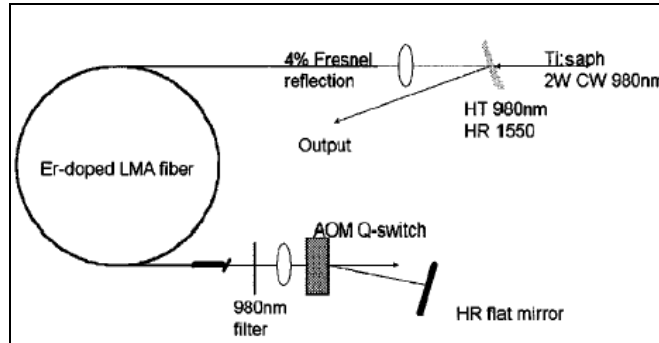

Fig. 9 Setup of Er-doped fiber laser with a large-mode-area fiber. [36]

The fiber geometry does have some drawbacks. Because of the small core size, fiber restricts the stored energy and leads to considerable nonlinear effects. Raman scattering and Brillouin scattering limit the available output powers of fiber lasers [24]. These effects must be controlled to get high power outputs. However, the core diameter of the fiber can be increased to decrease the power density inside the fiber, thus suppress the nonlinear effects from the fiber laser. Shorter fiber length also helps to increase nonlinear thresholds, though it may cause the a management problem [30].

In summary, to make fiber lasers generate high power output and keep the high beam quality, many kinds of techniques have been developed. Mode selection tapers, coiled fibers and large-mode-area fibers have been designed and demonstrated to eliminate higher-order modes. Nonlinear effects are thus suppressed to make high power densities in the fiber lasers available.

III. Experimental Results

A. CW High Power Fiber Lasers

A typical experiment setup of a CW ytterbium-doped fiber laser is shown in Fig. 10. In a 1999 implementation, the CW output of 110 W was achieved from such a laser. The conversion efficiency was measured to be about 58% [25]. In this experiment, high-brightness laser diode-bar packages were used as the pump sources. Polarization beam splitters were used to combine the pump sources to realize higher pump powers. The dichroic mirror DM1 was used as the end mirror, while DM2 acted as the output coupler. The aspheric lenses AL1 and AL2 were used to couple the pump beams into the double-clad fiber. With a scanning blade measurement, the beam quality factor M^2 was 1.7 at the 100 W level.

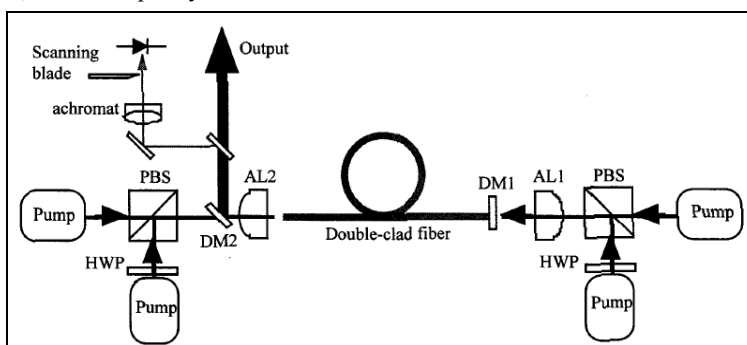

Fig. 10 Typical layout for a high-power fiber laser. PBS: polarization beam splitters, HWP: zero order half wave plates, AL: aspheric lenses, DM: dichroic mirrors. [25]

Two more experimental setups used in recent experiments are shown in Fig. 11 and Fig. 12 [26]. In the case of Fig. 11, the CW output of 80 W was achieved with a pump conversion efficiency of 59%. The beam quality of the YDFL was rather poor with a beam quality factor of 5 because the use of a multi-mode core with the V number of 11. In Fig. 12, a helical-core fiber was used to control the output mode. An output beam with the beam quality factor of 3 was achieved by using the helical-core double-clad fiber. When the pump was 50 W, the output power was 24.3 W indicating an optical efficiency of 48%. Thus the output beam quality was improved with the use of a helical fiber but the optical efficiency was somewhat deteriorated. Several other interesting experiments have been reported. In 2003, Limpert obtained 485 W output power with an beam quality factor of 1.5 from Yb:Nd codoped fiber [28]. Gapontsev demonstrated a CW output power of 400W with a beam quality factor of 1.05 from ytterbium-doped fiber laser in the same year [29].

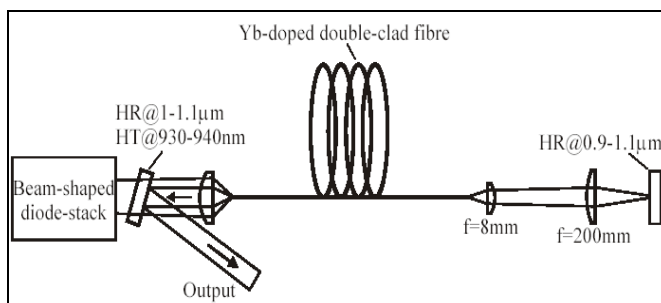

Fig. 11 Diode-stack-pumped Yb-doped fiber laser. [26]

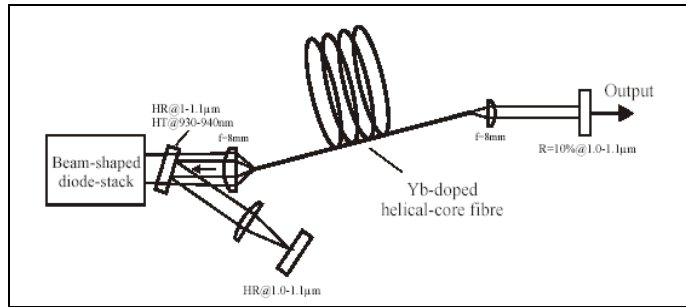

Fig. 12 Cladding pumped Yb-doped helical-core fiber laser. [26]

The recent record of CW high power fiber laser was realized by J. Nilsson and his coworkers in 2004 [27]. The output power of 1.36 kW was generated from this cladding-pumped ytterbium-doped fiber laser. The beam quality factor M^2 was 1.4, indicating near diffraction-limited beam quality. As shown in Fig. 13, diode stacks with a total power of 1.8 kW were used as the pump source. The laser worked at $1.1 \mu m$ with a 83% slope efficiency. The double-clad ytterbium-doped fiber was designed to have a D-shape inner cladding to increase the pump absorption efficiency. The fiber was bent with a diameter of about 20 cm to induce bending loss for higher-order modes without affecting the fundamental mode. Fig. 14 shows the output power as a function of input pump power and the spectrum of the fiber laser at the output power of 1.36 kW.

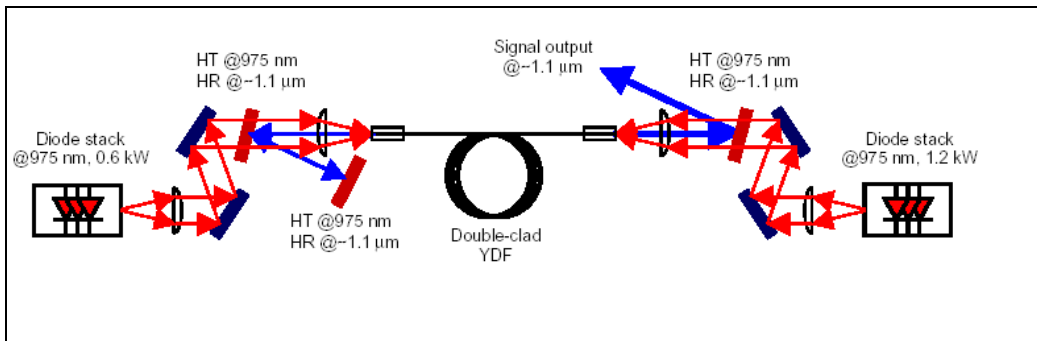

Fig. 13 Schematic of ytterbium doped double clad fiber laser, HR: high reflectivity, HT: high transmission. [27]

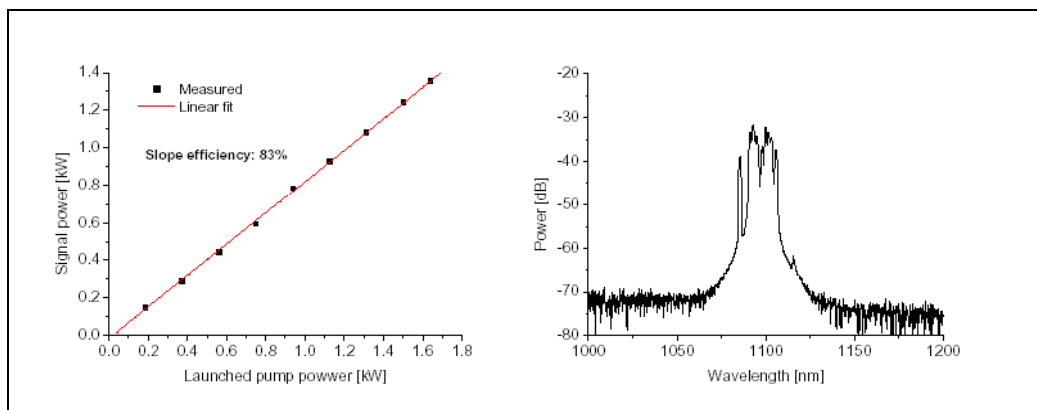

Fig. 14 Fiber output and input pump power curve and the laser output spectrum at 1.36 kW. [27]

Photonic crystal fibers have been increasingly playing an important role as optical components in optical systems. Such fibers consist of a periodic structure in the fiber cladding and they can guide light waves over a broad wavelength range. They have been also been used in high power fiber laser systems for mode selection and high-power generation. In 2003, Limpert ^[40] demonstrated a photonic crystal fiber laser with a large-mode-area (LMA) ytterbium doped fiber. Fig. 15 shows the cross section of the LMA photonic crystal fiber. The LMA fiber has a mode field area of $350 \mu\text{m}^2$. This field area generates a multimode output in a conventional step index fiber, but produces a single mode output beam in the designed photonic crystal fiber. Due to the large core, can reduce the nonlinear effects and provides benefits for nonlinear effects suppression. Fig. 16 shows the mode-field intensity distribution inside the photonic crystal fiber. The beam was nearly diffraction-limited with a beam quality factor of 1.2. Due to the small quantum defect of ytterbium, an optical efficiency of 78% was achieved. The output power was 80 W with a near diffraction-limited beam quality.

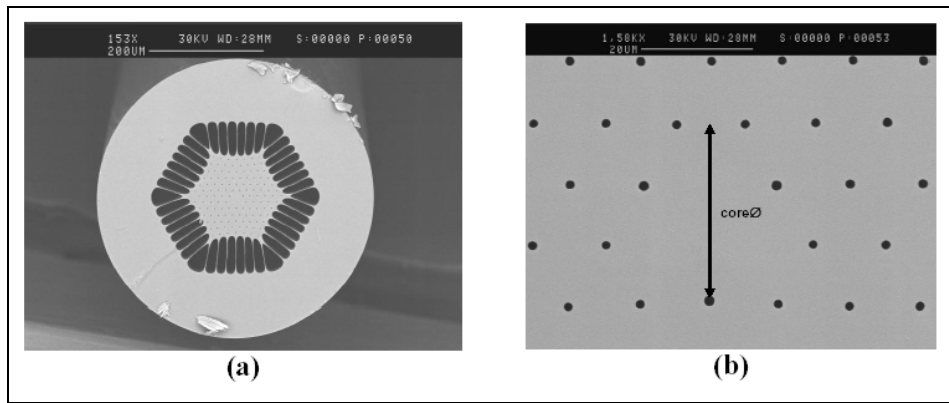

Fig. 15 Cross section of the proposed large-mode-area photonic crystal fiber. a: overall view, B: close-up of core region. ^[40]

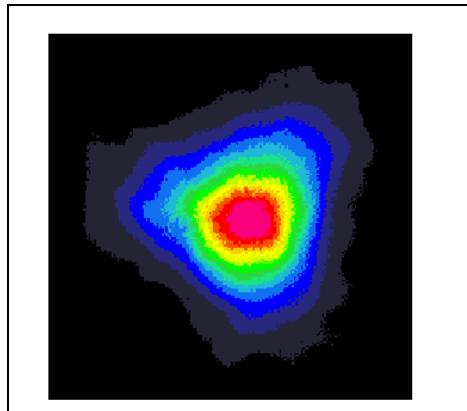

Fig. 16 Intensity distribution of the microstructure large-mode-area fiber laser output beam. ^[40]

Another kind of photonic crystal fiber with a uniform holey structure has been developed for high power fiber amplifiers and lasers in 2004 ^[41]. In the experiment Raman solitons were generated inside an ytterbium-doped holey fiber.

B. Pulsed High-Power Fiber Lasers

Pulsed high-power fiber lasers are needed for a variety of applications. Pulsed fiber lasers can be used for medical diagnostics, remote sensing, material processing, etc. For pulsed fiber lasers, Q-switching can be used to generate high average power pulses, while mode locked lasers can generate high peak power pulses.

Q-switching was proposed by Hellwarth in 1961^[31]. The available energy of a Q-switched laser pulse is determined by the number of excited ions in the active medium and the excited-state lifetime. The energy in one single pulse can be increased by either increasing the doping concentration or increasing the fiber core area. There is an upper limit for the ion concentration in silica because of the clustering of the rare-earth ions. On the other hand, the core area of a fiber is limited by the single-mode operation requirement. To let the laser generate single mode output with large core area, the numerical aperture (NA) of the fiber has to be small. In the low NA situation, a single-mode pump laser was used to get better coupling efficiency.

Semiconductor saturable-absorber mirrors (SESAM) can be used as nonlinear absorbers in passively Q-switched fiber lasers. In Paschotta's paper^[33], a SESAM was used as the nonlinear component to generate high energy pulses in a master-oscillator/power-amplifier (MOPA) configuration. As shown in Fig. 17, a dichroic mirror was used for pump and output couplers. The LMA fiber consisted of a 60-cm active section and a 78-cm amplifier section, each with a large mode area of $300 \mu\text{m}^2$. The oscillator was configured for six bounces on the SESAM. This fiber laser system generated 1-kHz repetition rate pulses, each with 0.11 mJ energy. The repetition rate could be increased with the pump power. The pulse width was about 10 ns with a peak power of 1 kW.

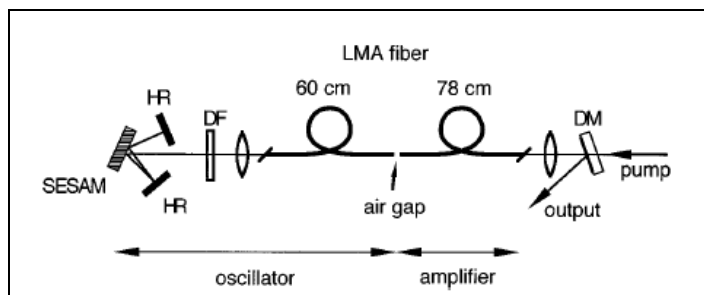

Fig. 17 Q-switched MOPA system made from a large-mode-area(LMA) fiber and a SESAM.^[33]

Active Q-switching can achieve a stable repetition rate and high output peak power pulses. Lees^[35] demonstrated a Q-switched erbium doped fiber laser with an acoustic-optic modulator (AOM) in 1997. Pulses of over 2 kW peak power and 25 ns pulse widths were obtained. The repetition was 500 Hz. In 1998, Offerhaus realized a single-mode output laser beam of beam quality factor $M^2 < 1.2$ in a doped multimode fiber^[36]. The active fiber was carefully designed to have large mode area. Fig. 9 shows the experimental setup of the single spatial mode fiber laser, which delivered 0.5 mJ of energy in each pulse.

With a LMA fiber, Alavez-Chavez demonstrated a high-energy Q-switched fiber laser in 2000^[39]. The AOM was used to modulate the Q-factor of the laser cavity. 2.3 mJ pulses were generated with a repetition of 500 Hz. The average output power reached 5 W with a beam quality factor M^2 of 3. The working wavelength was 1090 nm. As shown in Fig. 19, ytterbium-doped LMA fiber was used as the active medium.

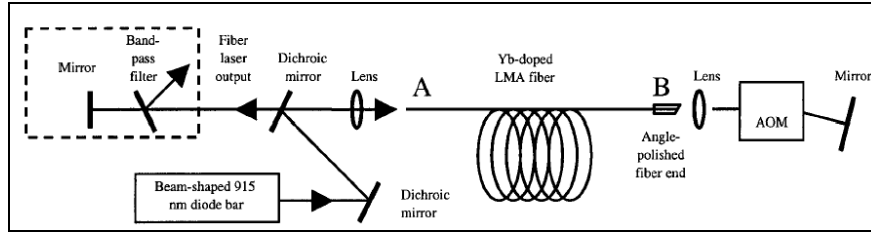

Fig. 18 Experimental setup of Q-switched Yb-doped fiber laser. [39]

Distributed Rayleigh scattering and Brillouin scattering can be used for Q-switched fiber lasers [32]. In these situations, pulse widths are determined by stimulated Brillouin scattering. The Brillouin backscattering changed the Q factor of the cavity in an unstable way. In Chen's paper [34], A hybrid Q-switching technique was demonstrated experimentally. The fiber backscattering and AOM were used for Q-switching. Fig. 19 shows the hybrid Q-switching setup. The double-clad neodymium-doped fiber was designed to have a rectangular inner cladding to increase the optical absorption efficiency. Peak powers of 3.7 kW and pulse durations of 2 ns were achieved.

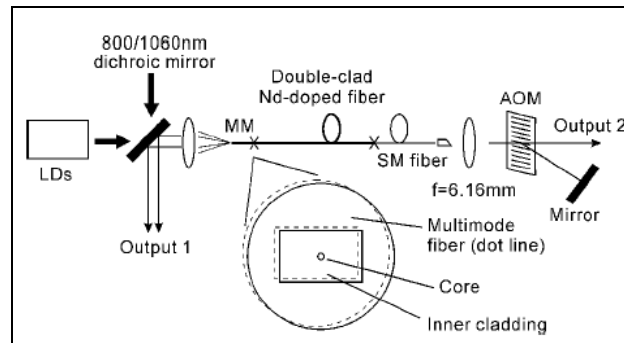

Fig. 19 Setup of an enhanced Q-switched Nd^{3+} fiber laser: LD, laser diode; MM, multimode fiber. [34]

In a 2004 experiment, Fan demonstrated a tunable Q-switched ytterbium-doped double clad fiber laser by using hybrid Q-switching [38]. The fiber laser was Q-switched using an acoustic-optic modulator (AOM) and stimulated Brillouin scattering. As shown in Fig. 20, a diffraction grating was used for tunable wavelength selection. The pulses had a repetition of 1.5 kHz, with a peak power of 153 kW and an average power of 1.17 W. The pulse width was 4.2 ns.

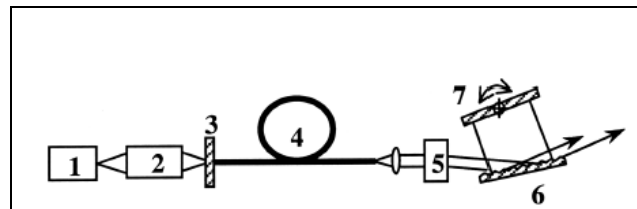

Fig. 20 Schematic of tunable Q-switched fiber laser 1: pump LD, 2: coupling lens, 3: dichroic mirror, 4: Yb-doped double clad fiber, 5: AOM, 6: diffraction grating, 7: high reflection mirror. [38]

Mode locking can generate high peak power pulses from fiber lasers. Mode locking was first demonstrated by Gurs and Muller [43][44] with ruby lasers and Statz and Tang [45] with He-Ne lasers. In mode-locked fiber lasers, pulsed radiation is produced by locking the relative phases of modes in the fiber cavity.

A saturable absorber can be used for mode locking provided it responds fast enough to change of the pulse intensity. With the intensity-dependent response, saturable absorbers can generate output pulses shorter than the input pulses. Collings demonstrated a mode locked fiber laser with a saturable absorber (reflector)^[46]. 270 fs pulses were generated with an average power of 1.6 mW. A Nonlinear fiber loop mirrors (NLM) can be used to replace saturable absorbers to maintain the all-fiber nature of fiber lasers. The NLM based mode-locked fiber laser was first demonstrated by Nakazawa in 1991^[47]. Intensity-dependent changes in the state of polarization can also be used for mode locking. In 1993, Tamura demonstrated 76 fs and 1 kW peak power pulses from a mode-locked fiber ring laser using intensity-dependent-polarization^[48].

Hybrid mode-locking combines the active and passive components inside the cavity of a mode-locked laser. The modulator can be operated at higher repetition rates to generate higher repetition rate pulses. This mechanism is known as harmonic mode-locking. A fiber ring laser with a harmonic mode locking was demonstrated by Nakazawa in 2000^[49]. With electronic absorption (EA) modulators and harmonic mode locking, pulses with 2.2 ps duration and 40 GHz repetition rate were generated in this experiment.

IV. Conclusions

Techniques for achieving high-power, high-beam-quality, fiber lasers have been explored. The double-cladding pump structure, large-mode-area fibers, helical-coiled fibers, mode-selection tapers, photonic crystal fibers have been investigated for high power fiber lasers with a high beam quality. The current results show that 1.36 kW CW fiber laser, 5 W average power pulsed fiber laser and 153 kW peak power pulsed laser with good beam qualities have been achieved.

References

1. T. H. Mainman, "Optical and microwave optical experiments in Ruby," *Physical Review Letters*, Vol. 4 No. 11, 564-566, 1960.
2. E. Snitzer, "Proposed Fiber Cavities for optical masers," *Journal of Applied Physics*, Vol. 32, No. 1, 36, 1961.
3. E. Snitzer, "Optical maser action in Nd³⁺ in a Barium crown glass," *Physical Review Letters*, Vol. 7, No. 12, 444-446, 1961.
4. C. A. Burrus, J. Stone, "Nd³⁺ doped SiO₂ lasers in an end-pumped fiber geometry," *Applied Physics Letters*, Vol. 23, No. 7, 388-389, 1973.
5. R. J. Mears, L. Reekie, I. M. Juancey, D. N. Payne, "Low-noise Erbium-doped fiber amplifier operating at 1.54 μ m," *Electronics Letters*, Vol. 23, No. 19, 1026-1028, 1987.
6. H. W. Etzel, H. W. Gandy, R. J. Ginther, "Stimulated emission of infrared radiation from Ytterbium-activated silica glass," *Applied Optics*, Vol. 1, 534, 1962.
7. A. E. Siegman, "Defining and measuring laser beam quality," in *Solid State Lasers: New Developments and Applications*, Inguscio M. and Wallenstein R. Eds., Plenum Press, USA 1993.
8. H. M. Pask, R. J. Carman, D. C. Hanna, A. C. Tropper, C. J. Mackechnie, P. R. Barber, J. M. Dawes, "Ytterbium-Doped Silica Fiber Lasers: Versatile Sources for the 1-1.2 μ m Region," *IEEE Journal of Selected Topics in Quantum Electronics*, Vol. 1, No. 1, April 1995.
9. R. Oron, D. Bunimovich, L. Nagli, A. Katzir, A. A. Hardy, "Design considerations for rare earth doped silver

-
- halide fiber amplifiers,” *Opt. Eng.* Vol. 8 No. 40, 1516-1520, Aug. 2001.
10. T. Erdogan, “Fiber Grating Spectra,” *Journal of Lightwave Technology*, Vol. 15, No. 8, August 1997.
 11. S. B. Poole, D. N. Payne, M. E. Fermann, “Fabrication of low loss optical fibers containing rare-earth ions,” *Electronics Letters*, Vol. 21, 737-738, 1985.
 12. J. Stone and C.A. Burrus, “Neodymium-doped silica lasers in end-pumped fiber geometry,” *Applied Physics Letters*, Vol. 23, No. 7, 388-389 1973.
 13. L. N. Duling, L. Goldberg, J. F. Weller, “High-power, mode-locked Nd: Fiber laser pumped by an injection-locked diode array,” *Electronics Letters*, Vol. 24, No. 21, 1333-1334, 1988.
 14. H. Zellmer, U. Willamowski, A. Tunnermann, H. Welling, “High-power CW neodymium-doped fiber laser operating at 9.2 W with high beam quality,” *Optics Letters*, Vol. 20, No. 6, 1995.
 15. H. Zellmer, A. Tunnermann, H. Welling, V. Reichel, “Double-Clad Fiber Laser with 30W Output Power,” *OSA TOPS Vol. 16, Optical Amplifiers and Their Applications*, 1997.
 16. V. Dominic, S. MacCormack, R. Waarts, S. Sanders, S. Bicknese, R. Dohle, E. Wolak, P. S. Yeh, E. Zucker, “110W fiber laser,” in *Proc. Conference on Lasers and Electro-Optics*, Baltimore, MD, USA 1999, post-deadline paper CPD26.
 17. J. Limpert, A. Liem, S. Hofer, H. Zellmer, and A. Tunnermann, “150W Nd/Yb codoped fiber laser at 1.1 μ m,” in *OSA trends in Optics and Photonics(TOPS) Vol. 73, Conference on Lasers and Electro-Optics*, OSA Technical Digest, 590-591, 2002.
 18. N. S. Platonov, D. V. Gapontsev, V. P. Gapontsev, V. Shumilin, “135W cw fiber laser with perfect single mode output,” in *Proc. Conference on Lasers and Electro-optics*, Long Beach, USA, 2002, post-deadline paper CPDC3.
 19. J. Nilsson, J. K. Sahu, Y. Jeong, W. A. Clarkson, R. Selvas, A. B. Grudinin, S. Alam, “High Power Fiber Lasers: New Developments,” *Advances in Fiber Devices, Proceedings of SPIE*, Vol. 4974, 2003.
 20. A. Liu, K. Ueda, “The absorption characteristics of circular, offset, and rectangular double-clad fibers,” *Optics Communications*, Vol. 132, 511-518, 1996.
 21. J. A. Alvarez-Chavez, H. L. Offerhaus, J. Nilsson, P. W. Turner, W. A. Clarkson, and D. J. Richardson, “High energy, high power ytterbium-doped Q-switched fiber laser,” *Optics Letters*, Vol. 25, 37-39, 2000.
 22. J. A. Alvarez-Chavez, A. B. Grudinin, J. Nilsson, P. W. Turner, and W. A. Clarkson, “Mode selection in high power cladding pumped fiber lasers with tapered section,” *Conference on Lasers and Electro-Optics*, OSA Technical Digest, 247-248, 1999.
 23. A. Galvanauskas, Z. Sartania, M. Bischoff, “Millijoule femtosecond fiber CPA system,” *Advanced Solid State Lasers*, Vol. 50, OSA trends in Optics and Photonics Series, 2001, postdeadline paper PD3.
 24. G. P. Agrawal, *Nonlinear Fiber Optics*, 2nd Ed., San Diego, CA, Academic Press, Inc., 1995.
 25. V. Dominic, S. MacCormack, R. Waarts, S. Sanders, S. Bicknese, R. Dohle, E. Wolak, P. S. Yeh, E. Zucker, “110W Fiber Laser,” *Electronics Letters*, Vol. 35, No. 14, 8th, July 1999.
 26. W. A. Clarkson, L. J. Cooper, P. Wang, R. B. Williams, J. K. Sahu, “Power scaling concepts for fiber lasers,” *Trends in Optics and Photonics*, Vol. 83, 261-267, 2003.
 27. Y. Jeong, J. K. Sahu, D. N. Payne, J. Nilsson, “Ytterbium-doped large-core fiber laser with 1.36 kW continuous-wave output power,” Vol. 12, No. 25, 6088-6092, *Optics Express*, 2004.
 28. J. Limpert, A. Liem, H. Zellmer, A. Tuennermann, “Continuous-wave ultra high brightness fiber laser systems,” *Proc. Advanced Solid-State Photonics 2003*, San Antonio, USA, 2003, postdeadline paper PD1.
 29. V. P. Gapontsev, N. S. Platonov, O. Shkuribin, L. Zaitsev, “400W low-noise single-mode CW ytterbium fiber laser with an integrated fiber delivery,” *Proc. Conference on Lasers and Electro-Optics 2003*, Baltimore, USA 2003, postdeadline paper CThPDB9.

-
30. D. C. Brown and H.J. Hoffmann, "Thermal, stress, and thermo-optic effects in high average power double-clad silica fiber lasers," *IEEE Journal of Quantum Electronics*, Vol. 37, 207-217, 2001.
 31. R. W. Hellwarth, "Theory of the Pulsation of Fluorescent Light from Ruby," *Physical Review Letters*. Vol. 6, 9-12 Jan. 1961.
 32. S. V. Chernikov, Y. Zhu, J. R. Taylor, "Supercontinuum self-Q-switched ytterbium fiber laser," *Optics Letters*, Vol. 22, No. 5, 1997.
 33. R. Paschotta, R. Haring, E. Gini, H. Melchior, U. Keller, "Passively Q-switched 0.1mJ fiber laser system at 1.53 μ m," *Optics Letters*, Vol. 24, No. 6, 1999.
 34. Z. J. Chen, A. B. Grudinin, J. Porta, J. D. Minelly, "Enhanced Q switching in double-clad fiber lasers," *Optics Letters*, Vol. 23, No. 6, 1998.
 35. G. P. Lees, D. Taverner, D. J. Richardson, L. Dong, T. P. Newson, "2kW Peak Power Q-switched Erbium Doped Fiber Laser," *Advanced Solid State Lasers*, 27-29, Jan. 1997.
 36. H. L. Offerhaus, N. G. Broderick, and D. J. Richardson, "High energy single-transverse-mode Q-switched fiber laser based on a multimode large-mode-area erbium-doped fiber," *Optics Letters*, Vol. 23, No. 21, 1998.
 37. C. C. Renaud, H. L. Offerhaus, J. A. Alvarez-Chavez, J. Nilsson, P. W. Turner, W. A. Clarkson, A. B. Grudinin, "Designs for efficient high-energy high brightness Q-switched cladding-pumped ytterbium-doped fiber lasers," *CLEO 2000*, San Francisco 7-12, May 2000.
 38. Ya-Xian Fan, Fu-Yun Lu, Shu-Ling Hu, Ke-Cheng Lu, Hong-Jie Wang, Xiao-Yi Dong, Jing-Liang He, Hui-Tian Wang, "Tunable high-peak-power, high-energy hybrid Q-switched double-clad fiber laser," *Optics Letters*, Vol. 29, No. 7, April 2004.
 39. J. A. Alvarez-Chavez, H. L. Offerhaus, J. Nilsson, P. W. Turner, W. A. Clarkson, D. J. Richardson, "High-energy high-power ytterbium-doped Q-switched fiber laser," *Optics Letters*, Vol. 25, No. 1, 2000.
 40. J. Limpert, T. Schreiber, S. Nolte, H. Zellmer, A. Tunnermann, "High-power air-clad large-mode-area photonic crystal fiber laser," Vol. 11, No. 7, 818-823, *Optics Express*, April, 2003.
 41. D. J. Richardson, K. Furusawa, T. Kogure, J. H. V. P. Price, J. H. Lee, T. M. Monro, "Holey fiber amplifiers and lasers," *ECOC 2004*, Stockholm 5-9 Sept. 2004 Th1.3.1.
 42. J. P. Kopolow, D. A. Kliner, L. Goldberg, "Single-mode operation of a coiled multimode fiber amplifier," *Optics Letters*, Vol. 25, No.7, 442-444, 2000.
 43. K. Gurs and R. Muller, "Breitband-modulation durch Steuerung der emission eines optischen masers (Auskopple-mudulation)," *Phys. Lett.*, Vol. 5, 179-181, 1963.
 44. K. Gurs, "Beats and modulation in optical ruby lasers," *Quantum Electronics III*, P. Grivet and N. Bloembergen, Eds, New York, Columbia University Press, 1113-1119, 1964.
 45. H. Statz and C. L. Tang, "Zeeman effect and nonlinear interactions between oscillating laser modes," *Quantum Electronics III*, P. Grivet and N. Bloembergen, Eds, New York, Columbia University Press, 469-498, 1964.
 46. B. C. Collings, K. Bergman, W. H. Knox, "Stable multigigahertz pulse-train formation in a short-cavity passively harmonic mode-locked erbium/ytterbium fiber laser," *Optics Letters*, Vol. 23, No. 2, 123-125, 1998.
 47. M. Nakazawa, E. yoshida, Y. Kimura, "Low threshold, 290 fs erbium-doped fiber laser with a nonlinear amplifying loop mirror pumped by InGaAsP laser diodes," *Applied Physics Letters*, Vol. 59, 2073-2075, 1991.
 48. K. Tamura, E. P. Ippen, H. A. Haus, L. E. Nelson, "77-fs pulse generation from a stretched-pulse mode-locked all-fiber ring laser," *Optics Letters*, Vol. 18, 1080-1082, 1993.
 49. M. Nakazawa, E. Yoshida, "A 40-GHz 850-fs Regeneratively FM Mode-locked Polarization-Maintaining Erbium Fiber Ring Laser," *IEEE Photonics Technology Letters*, Vol. 12, 1613-1615, 2000.
 50. E. Snitzer, R. Tumminelli, "SiO₂-clad fibers with selectively volatilized soft-glass cores," *Optics Letters*, Vol. 14, No. 14, 757-759, 1989.